

# BREATHING AIR CATALOG

High-Pressure Systems for Military & Government Applications



WORLDWIDE

QUALITY

INNOVATION

RELIABILITY





# GLOBAL PRESENCE WITH LOCAL SUPPORT





## MISSION STATEMENT

Our mission at BAUER COMPRESSORS INC. is to provide the highest quality products and solutions for high-pressure air and gas. We are committed to using the latest technology, best materials, most qualified human resources, and the most efficient fabrication techniques. As a result, our equipment solutions offer superior performance along with best value, and are delivered on time, defect-free and are supported to achieve their maximum potential throughout their entire lifecycle.

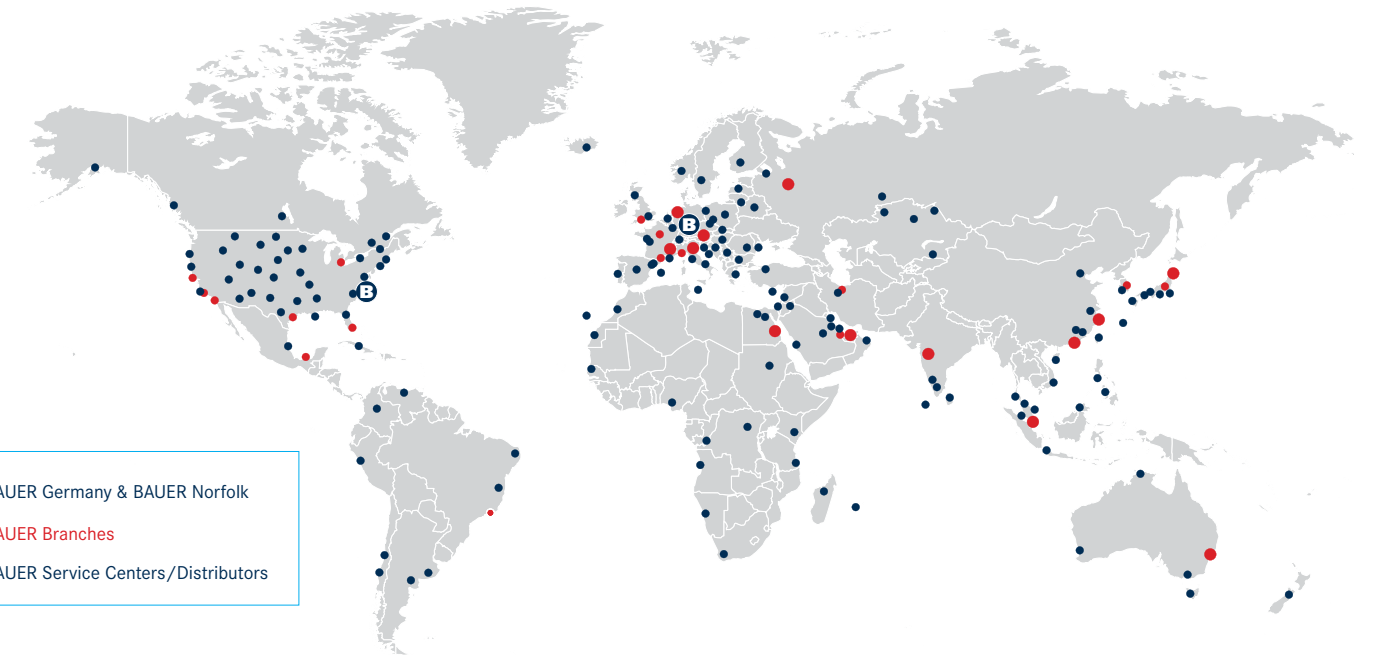
BAUER Corporate Headquarters: North American Manufacturing – Norfolk, Virginia



-  BAUER Germany & BAUER Norfolk
-  BAUER Branches
-  BAUER Service Centers/Distributors

## DISTRIBUTOR NETWORK

Supporting you after the sale is a global network of compressor specialists that is unmatched in the industry. Each of our trusted Distributor partners is staffed with BAUER Factory-Trained Technicians and is stocked with a full inventory of products and parts – insuring you receive unsurpassed 24/7 Customer Support, no matter where you are in the world.

Additionally, BAUER has U.S. Sales & Service operations that include branch offices in California and New York.



GLOBAL SUPPORT



SINGLE SOURCE RESPONSIBILITY



LOW COST OF OWNERSHIP



LIFECYCLE PERFORMANCE

## OUR EXPERIENCE. YOUR BENEFIT.

Our 75 years of experience continues to be a benefit to our worldwide customers by providing them with a diverse selection of field-proven high-pressure breathing air solutions. We are world renowned for reliability and durability, and BAUER as a company is recognized as the world's foremost innovative designer and manufacturer of high-pressure compressors of the very highest quality.

BAUER's state-of-the-art 250,000 square-foot facility in Norfolk, Virginia means we can stand behind all of the research and development in our breathing-air systems, which are made right here in the U.S.A.





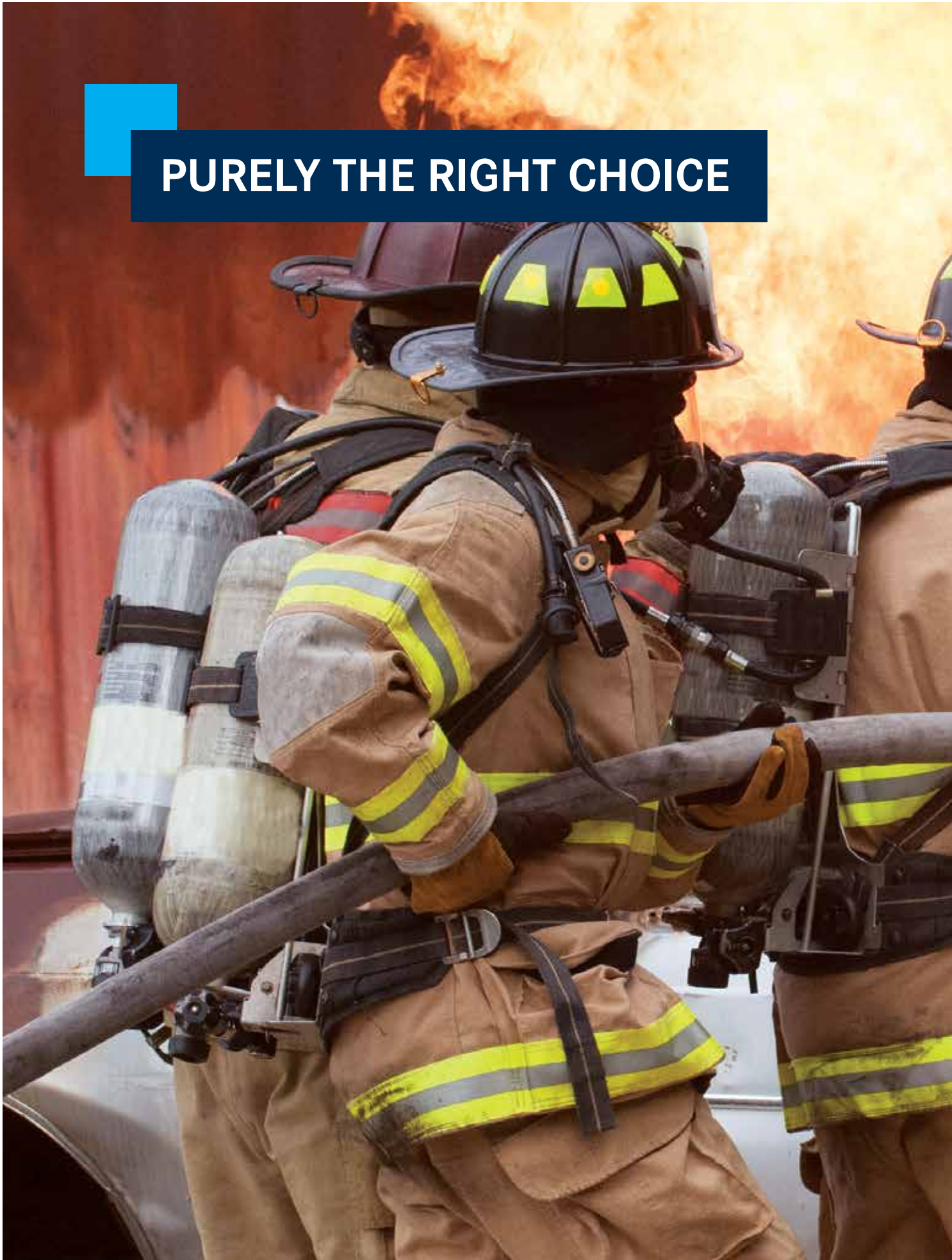

**PURELY THE RIGHT CHOICE**

# CONTENTS

## DIVE PRODUCTS

- › Portables ..... 6
- › DMT II ..... 26

## DIVE AND FIRE PRODUCTS

- › VERTECON® ..... 28
- › VERTICUS® ..... 30

## FIRE PRODUCTS

- › 7k Systems ..... 32
- › Plus Module ..... 38
- › UNICUS® 4S ..... 40
- › UNICUS® 4i ..... 42
- › O320-E/D ..... 46
- › O26D-ESSM ..... 48
- › O26-E3/ESSM ..... 50
- › Engine Driven ..... 52
- › DDTR26-WRAF ..... 54
- › TCOM® LITE Trailer ..... 56
- › TCOM® Trailer ..... 58
- › Mobile Package ..... 60
- › Open Designs ..... 62

## ACCESSORIES

- › CFS5.5® ..... 64
- › Air Storage ..... 66
- › BAUER CRC™ ..... 68
- › Purification ..... 70
- › BAUER B-Virus Free™ ..... 72
- › BAUER CONNECT® for Firefighters ..... 74
- › Quick Reference Guide ..... 76
- › Parts Quick Reference Guide ..... 78

## CUSTOMER SUPPORT

- › Parts, Service, Support & Training ..... 90

# PORTABLES

## 3-STAGE HIGH-PRESSURE BREATHING AIR COMPRESSORS

JUNIOR II and OCEANUS – include an air purification system and fill hose. These safe and reliable 3-stage compressors are designed for serious sport divers. Available in 1-phase 115/230 VAC and 3-phase 230/460 VAC electric motor or gasoline drives.

- › **PRESSURE:**  
5000 PSIG (345 BAR)
- › **CHARGING RATE:**  
2.9 to 4.9 SCFM  
(82 to 139 L/MIN)
- › **POWER:**  
2 to 6 HP (1.5 to 4.5 kW)

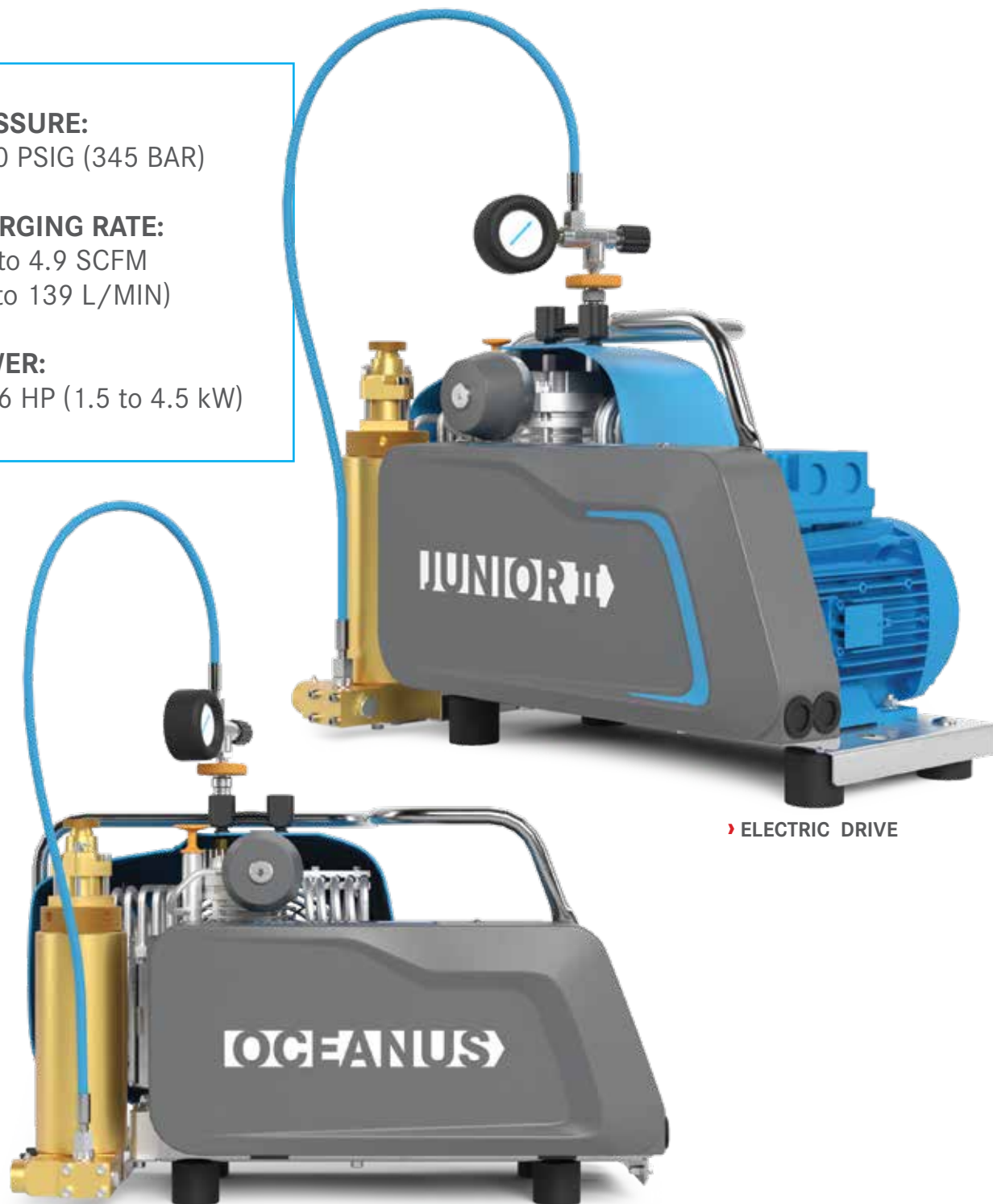

› ELECTRIC DRIVE

› ELECTRIC DRIVE

### STANDARD SCOPE OF SUPPLY

- › BAUER P0 breathing air purification system
- › Belt guard designed to meet OSHA guidelines
- › Inlet filter
- › Vibration isolators
- › High-temperature switch (G drives)
- › Five-foot fill hose assembly with SCUBA yoke, bleed valve and pressure gauge

### OCEANUS MODELS (ADD TO ABOVE)

- › Sturdy, long lasting low pressure oil pump
- › Large oil sump allows shipboard inclination of 30° (20° G drive)
- › Capable of filling/maintaining up to a two cylinder 5000 PSIG UN storage system
- › Corrosion-resistant coolers and stainless steel frame

### YACHTING PACKAGE (ADD TO ABOVE)

- › NEMA - 4 electrical box
- › Motor starter
- › Automatic condensate drain with muffler/separator and condensate reservoir
- › Pressure switch
- › Stainless steel fittings

### TECHNICAL DATA

Model	Charging Rate <sup>1</sup>		Number of Stages	Motor		FAD <sup>2</sup>	RPM	Purification System
	SCFM	L/MIN		HP	kW			
<b>JUNIOR II 5000 PSIG (345 BAR)</b>								
JRII-E1/115	2.9	82	3	2	1.5	2.5	1500	P0
JRII-E1	3.9	110	3	3	2.2	3.2	2100	P0
JRII-E3	3.9	110	3	3	2.2	3.2	2100	P0
JRII-GK	4.3	122	3	6	4.5	3.6	2300	P0
<b>JUNIOR II YACHTING PACKAGE</b>								
JRII-E1Y/115	2.9	82	3	2	1.5	2.5	1500	P0
JRII-E1Y	3.9	110	3	3	2.2	3.2	2100	P0
JRII-E3Y	3.9	110	3	3	2.2	3.2	2100	P0
<b>OCEANUS 5000 PSIG (345 BAR)</b>								
OCEANUS-E1	4.9	139	3	5	3.7	4.1	2150	P0
OCEANUS-E3	4.9	139	3	5	3.7	4.1	2150	P0
OCEANUS-GK	4.9	139	3	6	4.5	4.1	2150	P0
<b>OCEANUS YACHTING PACKAGE</b>								
OCEANUS-E1Y	4.9	139	3	5	3.7	4.1	2150	P0
OCEANUS-E3Y	4.9	139	3	5	3.7	4.1	2150	P0

Note: JRII is designed for filling an individual SCUBA or SCBA. It is neither designed nor intended for filling cascade storage systems of any kind. 1) Based on recharging an 80 cubic foot tank from 500 to 3000 psig. 2) Compressor capacity referenced to standard inlet conditions. E1/115= Single phase electric, 115 VAC/60 Hz. E1=Single phase electric, 230 VAC/60 Hz. E3=Three phase electric, 208/230/460 VAC/60 Hz. GK=Gasoline engine drive, KOHLER. Y=Yachting package. Dimensions and weight are approximate and are subject to change.

### AVAILABLE ACCESSORIES (FACTORY INSTALLED)

- › Visual CO/Moisture monitor indicator
- › Final pressure switch for gasoline engine
- › Hourmeter/Tachometer (G drive)
- › B-Timer

### SYSTEM FOOTPRINT

#### JUNIOR II:

DIMENSIONS L x W x H inches (mm)

- › JRII-E1/E3: 27" x 14" x 17" (686mm x 356mm x 432mm)
- › JRII-GK: 31" x 14" x 17" (787mm x 356mm x 432mm)
- › JRII-EY: 32" x 16" x 24" (813mm x 406.4mm x 610mm)
- › WEIGHT pounds (kg) 89 - 165 lb (40 - 75 kg)

#### OCEANUS:

DIMENSIONS L x W x H inches (mm)

- › OCEANUS-E1/E3: 27" x 17" x 17" (686mm x 432mm x 432mm)
- › OCEANUS-GK: 31" x 14" x 17" (787mm x 356mm x 432mm)
- › OCEANUS-EY: 32" x 20" x 17" (686mm x 432mm x 432mm)
- › WEIGHT pounds (kg) 96 - 135 lb (44 - 61 kg)



# JRII-E1/ARMY

## SCHEDULE MAS:

Total solutions for law enforcement, security, facilities management, fire, rescue, clothing, marine craft and emergency/disaster response.

**NAICS CODE #333912 | NSN: 4310-01-564-6677 | GSA CONTRACT: GS-07F-195GA**

When your needs call for a truly lightweight portable that can be plugged into a common household outlet, look to the JRII-E1/ARMY. This unit is commonly fielded for use on the MRS III Egress Air Manifold System and the Wilcox HP/LP Quick Fill Charging System.

› **PRESSURE:**  
3700 PSIG (255 BAR)

› **CHARGING RATE:**  
1.2 SCFM (34 L/MIN)

› **POWER:**  
1.5 HP (1.1 kW)

› **CONTRACT PERIOD:**  
09/25/22 - 09/24/27



› JRII-E1/ARMY

## STANDARD SCOPE OF SUPPLY

- › Air-cooled high pressure JUNIOR compressor
- › Electric motor 1.5 HP, 110 V
- › BAUER P0 air purification system to process 3,200 CF of air per cartridge at standard inlet conditions
- › 15 amp plug
- › Final pressure setting 3700 PSIG
- › Pressure maintaining valve
- › Check valve
- › Filter vent valve
- › Air outlet 1/4"
- › Lightweight, fixed base
- › Hourmeter
- › Visual CO/Moisture monitor indicator
- › Inlet filter
- › One 5 ft. fill hose complete with shut-off valve, pressure gauge, vent valve and 300 bar din adapter
- › 10 ft. electric cable with plug for 110 V 15 AMP circuit
- › Base mounted on/off switch

## AVAILABLE ACCESSORIES

- › P0 purification cartridge
- › Certified air test with documentation
- › Gasket kit
- › Valve overhaul kit
- › Inlet filter element
- › Fill gauge (Fill gauge with calibration option)
- › 5 ft. fill hose

## SYSTEM FOOTPRINT

### DIMENSIONS L x W x H inches (mm)

- › 29.375" x 14" x 16.25" (746mm x 356mm x 412.75mm)

### WEIGHT pounds (kg)

- › 100 lb (45 kg)

## TECHNICAL DATA

Model	Charging Rate <sup>1</sup>		Number of Stages	Motor		FAD <sup>2</sup>	RPM	Purification System
	SCFM	L/MIN		HP	kW			
<b>JUNIOR II 3700 PSIG (255 BAR)</b>								
JRII-E1/ARMY	1.2	34	3	1.5	1.1	1	2100	P0

1) Based on recharging an 80 cubic foot tank from 500 to 3000 psig.

2) Compressor capacity referenced to standard inlet conditions. Dimensions and weight are approximate and are subject to change.

A. BAUER COMPRESSOR warranty includes parts and labor 12 Months from the date of compressor start-up or 18 Months from the date of shipment. B. Spare parts consisting of normal wear and tear items, e.g., replacement cartridges, valve overhaul kits, gasket kits, belts, oil, inlet filter element, etc., are standard stock items at BAUER NORFOLK, BAUER SAN FRANCISCO, and BAUER NORTHEAST.

3) Maximum operating pressure with 1.5 HP motor and 15 amp plug is 1800 PSIG. 4) Maximum operating pressure with 20 HP motor and 20 amp plug is 5000 PSIG.

D  
I  
V  
E



# OCEANUS-E3/NAVY

## SCHEDULE MAS:

Total solutions for law enforcement, security, facilities management, fire, rescue, clothing, marine craft and emergency/disaster response.

**NAICS CODE #333912 | NSN: 4310-01-532-5897 | GSA CONTRACT: GS-07F-195GA**

When your needs specify a robust package that can be subjected to the rigors of outdoor use, look to the OCEANUS-E3/NAVY. Amenities including a stainless steel frame and ergonomically designed lifting handle coupled with a BAUER purification system and combination CO/Moisture indicator.

- › **PRESSURE:**  
5000 PSIG (345 BAR)
- › **CHARGING RATE:**  
4.9 SCFM (139 L/MIN)
- › **POWER:**  
5 HP (3.7 kW)
- › **CONTRACT PERIOD:**  
09/25/22 - 09/24/27



› OCEANUS-E3/NAVY

## STANDARD SCOPE OF SUPPLY

- › Air-cooled high pressure OCEANUS compressor
- › Electric motor 5 HP, 230 V/460 V
- › BAUER P0 air purification system to process 3,200 CF of air per cartridge at standard inlet conditions
- › Pressure maintaining valve
- › Check valve
- › Filter vent valve
- › Air outlet 1/4"
- › Lightweight, fixed stainless steel base
- › Hourmeter
- › Visual CO/Moisture monitor indicator
- › Inlet filter
- › One 5 ft. fill hose complete with shut-off valve, pressure gauge, vent valve and CGA-347 adapter
- › Electric cable with strain relief

## AVAILABLE ACCESSORIES

- › P0 purification cartridge
- › Certified air test with documentation
- › Gasket kit
- › Inlet filter element
- › Valve overhaul kit
- › 5 ft. fill hose
- › Fill gauge ( Fill gauge with calibration option)
- › Gasket, O-ring and seals kit
- › Plug for 440 VAC

## SYSTEM FOOTPRINT

### DIMENSIONS L x W x H inches (mm)

- › 32" x 18" x 23" (813mm x 457mm x 584mm)

### WEIGHT pounds (kg)

- › 135 lb (61 kg)

## TECHNICAL DATA

Model	Charging Rate <sup>1</sup>		Number of Stages	Motor		FAD <sup>2</sup>	RPM	Purification System
	SCFM	L/MIN		HP	kW			
<b>5000 PSIG (345 BAR)</b>								
OCEANUS-E3/NAVY	4.9	139	3	5	3.7	4.1	2150	P0

1) Based on recharging an 80 cubic foot tank from 500 to 3000 psig.  
 2) Compressor capacity referenced to standard inlet conditions. Dimensions and weight are approximate and are subject to change.  
 A. BAUER COMPRESSOR warranty includes parts and labor 12 Months from the date of compressor start-up or 18 Months from the date of shipment.  
 B. Spare parts consisting of normal wear and tear items, e.g., replacement cartridges, valve overhaul kits, gasket kits, belts, oil, inlet filter element, etc., are standard stock items at BAUER NORFOLK, BAUER SAN FRANCISCO, and BAUER NORTHEAST.

DIVE

DIVE



# OCEANUS-E3Y

## SCHEDULE MAS:

Total solutions for law enforcement, security, facilities management, fire, rescue, clothing, marine craft, and emergency/disaster response.

**NAICS CODE #333912 | GSA CONTRACT: GS-07F-195GA**

Includes many amenities found only on higher capacity systems, including pressure lubricated 3-stage compressor, automatic condensate drain system, automatic air switch, NEMA-4 electrical enclosure, stainless steel frame, high temperature shutdown switch, all coupled to a BAUER purification system.

- › **PRESSURE:**  
5000 PSIG (345 BAR)
- › **CHARGING RATE:**  
4.9 SCFM (139 L/MIN)
- › **POWER:**  
5 HP (3.7 kW)
- › **CONTRACT PERIOD:**  
09/21/17 - 09/20/22



› OCEANUS-E3Y



## STANDARD SCOPE OF SUPPLY

- › Heavy duty stainless steel base and stainless steel inner frame
- › Compressor base plate with stainless steel fittings
- › Magnetic starter and power-on light
- › High temperature and final pressure switch
- › Hourmeter and on/off switch
- › Automatic condensate drain system
- › Safety relief valves for each stage of compression
- › Inlet filter and oil dipstick
- › Vibration isolators and belt guard
- › NEMA 4x electric enclosure
- › BAUER P0 purification system
- › UV resistant molded plastic flywheel cover
- › BAUER Oceanus air-cooled high pressure compressor

## AVAILABLE ACCESSORIES

- › P0 purification cartridge
- › Certified air test with documentation
- › Gasket kit
- › Valve overhaul kit
- › Inlet filter element
- › Fill gauge ( Fill gauge with calibration option)
- › 5 ft. fill hose
- › Gasket, O-ring and seals kit

## SYSTEM FOOTPRINT

### DIMENSIONS L x W x H inches (mm)

- › 32" x 18" x 23" (813mm x 457mm x 584mm)

### WEIGHT pounds (kg)

- › 135 lb (61 kg)

## TECHNICAL DATA

Model	Charging Rate <sup>1</sup>		Number of Stages	Motor		FAD <sup>2</sup>	RPM	Purification System
	SCFM	L/MIN		HP	kW			
<b>5000 PSIG (345 BAR)</b>								
OCEANUS-E3Y	4.9	139	3	5	3.7	4.1	2150	P0

1) Based on recharging an 80 cubic foot tank from 500 to 3000 psig.  
 2) Compressor capacity referenced to standard inlet conditions. Dimensions and weight are approximate and are subject to change.  
 A. BAUER COMPRESSOR warranty includes parts and labor 12 Months from the date of compressor start-up or 18 Months from the date of shipment.  
 B. Spare parts consisting of normal wear and tear items, e.g., replacement cartridges, valve overhaul kits, gasket kits, belts, oil, inlet filter element, etc., are standard stock items at BAUER NORFOLK, BAUER SAN FRANCISCO, and BAUER NORTHEAST.



# OCEANUS-E3Y/NOAA

## SCHEDULE MAS:

Total solutions for law enforcement, security, facilities management, fire, rescue, clothing, marine craft and emergency/disaster response.

**NAICS CODE #333912 | GSA CONTRACT: GS-07F-195GA**

When your needs call for a total solution at a budgetary price, look to BAUER. Our continuous duty OCEANUS-E3Y coupled to a two (2) bottle storage bank and two (2) position containment fill station will fulfill your needs.

- › **PRESSURE:**  
5000 PSIG (345 BAR)
- › **CHARGING RATE:**  
4.9 SCFM (139 L/MIN)
- › **POWER:**  
5 HP (3.7 kW)
- › **CONTRACT PERIOD:**  
09/25/22 - 09/24/27



› HC5000-2



› CFS5.5-2S



› OCEANUS-E3Y/NOAA

## STANDARD SCOPE OF SUPPLY

- › Heavy duty stainless steel base and stainless steel inner frame
- › Compressor base plate with stainless steel fittings
- › Magnetic starter and power-on light
- › High temperature and final pressure switch
- › Hourmeter and on/off switch
- › Automatic condensate drain system
- › Safety relief valves for each stage of compression
- › Inlet filter and oil dipstick
- › Vibration isolators and belt guard
- › NEMA 4x electric enclosure
- › P0 purification system
- › UV resistant molded plastic flywheel cover

## HC5000-2

- › Two (2) each 5000 PSIG UN code stamped cylinders mounted in a vertical rack
- › Price includes cylinder intergrated piping

## CFS5.5-2S

- › 2 Position SCBA containment fill station

## AVAILABLE ACCESSORIES

- › P0 purification cartridge
- › Certified air test with documentation
- › Gasket kit
- › Valve overhaul kit
- › Inlet filter element
- › Fill gauge ( Fill gauge with calibration option)
- › 5 ft. fill hose
- › Gasket, O-ring and seals kit

## TECHNICAL DATA

Model	Charging Rate <sup>1</sup>		Number of Stages	Motor		FAD <sup>2</sup>	RPM	Purification System
	SCFM	L/MIN		HP	kW			
OCEANUS-E3Y/NOAA	4.9	139	3	5	3.7	4.1	2150	P0

1) Based on recharging an 80 cubic foot tank from 500 to 3000 psig.  
 2) Compressor capacity referenced to standard inlet conditions. Dimensions and weight are approximate and are subject to change.  
 A. BAUER COMPRESSOR warranty includes parts and labor 12 Months from the date of compressor start-up or 18 Months from the date of shipment.  
 B. Spare parts consisting of normal wear and tear items; e.g., replacement cartridges, valve overhaul kits, gasket kits, belts, oil, and inlet filter element, etc. are standard stock items at BAUER NORFOLK, BAUER SAN FRANCISCO, and BAUER NORTHEAST



# C-D/DV/NAVY

(This product available to our US Navy customers only)

## SCHEDULE MAS:

Total solutions for law enforcement, security, facilities management, fire, rescue, clothing, marine craft and emergency/disaster response.

**NAICS CODE #333912 | NSN: 4310-01-465-1509 | GSA CONTRACT: GS-07F-195GA**

Whether your requirement is filling an SCBA or SCUBA cylinder look to the C-D/DV/NAVY to fulfill your portable needs. A rugged lightweight steel tubular frame supports all pressure bearing components while at the same time provides the ultimate in portability.

- › **PRESSURE:**  
5000 PSIG (345 BAR)
- › **CHARGING RATE:**  
6 SCFM (170 L/MIN)
- › **POWER:**  
6 HP (4.5 kW)
- › **CONTRACT PERIOD:**  
09/25/22 - 09/24/27

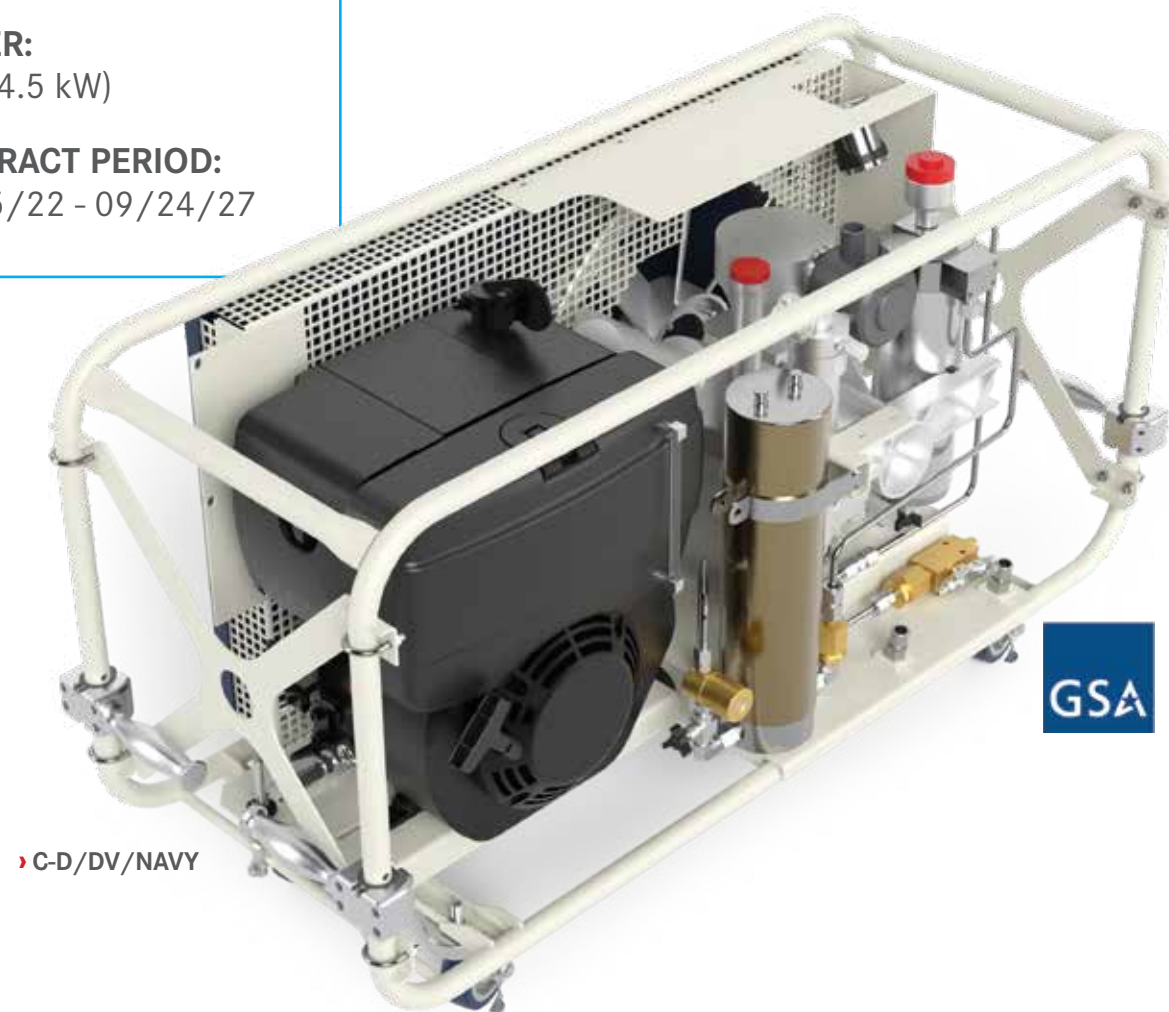

› C-D/DV/NAVY

## STANDARD SCOPE OF SUPPLY

- › Air-cooled high pressure CAPITANO compressor
- › Yanmar air-cooled diesel engine with 2.7 quart fuel tank
- › BAUER P1 breathing air purification system to process 15,000 CF of air per cartridge at standard inlet conditions (2 replacements)
- › Pressure maintaining valve
- › Check valve
- › Vent valve
- › Air outlet 1/4", with tee installed
- › Lightweight, tubular metal frame
- › Retractable carrying handles (4)
- › Heavy duty casters (4)
- › Hourmeter
- › Visual CO/moisture monitor indicator
- › Two 6 ft. fill hoses, each hose complete with shut-off valve, pressure gauge, vent valve and CGA-347 adapter or C-D/DV/NAVY/SF (SCUBA)
- › Austenitic stainless steel tubing, tube fittings and fill hose fittings, high pressure instrument pipe fittings and anodized aluminum fill adapters
- › Inlet filter with 10 ft. flexible hose

## AVAILABLE ACCESSORIES

- › P1 purification cartridge
- › Certified air test with documentation
- › Intake filter
- › Fill hose assembly
- › Gasket, fill hose assembly, calibrated
- › Fill adapter

## SYSTEM FOOTPRINT

### DIMENSIONS L X W X H inches (mm)

- › 45.375" x 18.625" x 28.875" (1153mm x 473mm x 733mm)

### WEIGHT pounds (kg)

- › 262 lb (119 kg)

## TECHNICAL DATA

Model	Charging Rate <sup>1</sup>		Number of Stages	Motor		FAD <sup>2</sup>	RPM	Purification System
	SCFM	L/MIN		HP	kW			
<b>5000 PSIG (345 BAR) NSN 4310-01-465-1509</b>								
C-D/DV/NAVY	6	170	3	6	4.5	5	1250	P1

1) Based on recharging an 80 cubic foot tank from 500 to 3000 psig.

2) Compressor capacity referenced to standard inlet conditions. Dimensions and weight are approximate and are subject to change.

A. BAUER COMPRESSOR warranty includes parts and labor 12 Months from the date of compressor start-up or 18 Months from the date of shipment.

B. Spare parts consisting of normal wear and tear items, e.g., replacement cartridges, valve overhaul kits, gasket kits, belts, oil, inlet filter element, etc., are standard stock items at BAUER NORFOLK, BAUER SAN FRANCISCO, and BAUER NORTHEAST.

# C-D/DV/NAVY/SS

(This product available to our US Navy customers only)

## SCHEDULE MAS:

Total solutions for law enforcement, security, facilities management, fire, rescue, clothing, marine craft and emergency/disaster response.

**NAICS CODE #333912 | NSN: 4310-01-541-4359 | GSA CONTRACT: GS-07F-195GA**

Whether your requirement is filling an SCBA or SCUBA cylinder, look to the C-D/DV/NAVY/SS to fulfill your portable needs. A rugged stainless steel frame and optional cover assures all pressure bearing components are protected, even in the most severe conditions.

- › **PRESSURE:**  
5000 PSIG (345 BAR)
- › **CHARGING RATE:**  
6 SCFM (170 L/MIN)
- › **POWER:**  
6 HP (4.5 kW)
- › **CONTRACT PERIOD:**  
09/25/22 - 09/24/27



› C-D/DV/NAVY/SS

## STANDARD SCOPE OF SUPPLY

- › Air-cooled high pressure CAPITANO compressor
- › Marinized Yanmar air-cooled diesel engine with 2.7 quart fuel tank (Muffler and throttle bracket nickel plated for corrosion inhibition)
- › BAUER P1 breathing air purification system to process 15,000 CF of air per cartridge at standard inlet conditions (2 replacements)
- › Pressure maintaining valve
- › Check valve
- › Vent valve
- › Air outlet 1/4", with tee installed
- › Visual CO/moisture monitor indicator
- › Two 6ft. fill hoses, each hose complete with shut-off valve, pressure gauge, vent valve and CGA-347 adapter or C-D/DV/NAVY/SF (SCUBA)
- › Austenitic stainless steel tubing, tube fittings and fill hose fittings, high pressure instrument pipe fittings and anodized aluminum fill adapters
- › Inlet filter with 10 ft. flexible hose
- › Stainless steel: frame with integral skid plate, cover with retractable lifting handles and tie down points, cover latches and four-point mounted casters (brakes and are independently steerable)
- › Compressor and cover lifting handles (operator comfort)
- › Oil drain hoses for the compressor and diesel engine
- › Enhanced fill hose retainer attachment points
- › Metal interstage relief valve tagging

## AVAILABLE ACCESSORIES

- › P1 purification cartridge
- › Cover
- › Certified air test with documentation
- › Intake filter
- › Fill hose assembly
- › Gasket, fill hose assembly, calibrated
- › Fill adapter

## SYSTEM FOOTPRINT

- DIMENSIONS L X W X H inches (mm)**
- › 52" x 21.375" x 29" (1321mm x 543mm x 737mm)
- DRY WEIGHT pounds (kg)**
- › **Without cover:** 322 lb (146 kg)
  - › **Cover:** 64 lb (29 kg)
  - › **Total weight:** 386 lb (175 kg)

## TECHNICAL DATA

Model	Charging Rate <sup>1</sup>		Number of Stages	Motor		FAD <sup>2</sup>	RPM	Purification System
	SCFM	L/MIN		HP	kW			
<b>5000 PSIG (345 BAR) NSN 4310-01-541-4359</b>								
C-D/DV/NAVY/SS	6	170	3	6	4.5	5	1250	P1

1) Based on recharging an 80 cubic foot tank from 500 to 3000 psig.  
 2) Compressor capacity referenced to standard inlet conditions. Dimensions and weight are approximate and are subject to change.  
 A. BAUER COMPRESSOR warranty includes parts and labor 12 Months from the date of compressor start-up or 18 Months from the date of shipment.  
 B. Spare parts consisting of normal wear and tear items, e.g., replacement cartridges, valve overhaul kits, gasket kits, belts, oil, inlet filter element, etc., are standard stock items at BAUER NORFOLK, BAUER SAN FRANCISCO, and BAUER NORTHEAST.

DIVE

DIVE



# C-D/DV/MU

(Available to all US Military, DOD and Schedule 84 customers)

## SCHEDULE MAS:

Total solutions for law enforcement, security, facilities management, fire, rescue, clothing, marine craft and emergency/disaster response.

### NAICS CODE #333912 | GSA CONTRACT: GS-07F-195GA

Whether your requirement is filling an SCBA or SCUBA cylinder look to the C-D/DV/MU to fulfill your portable needs. A rugged lightweight steel tubular frame supports all pressure bearing components while at the same time provides the ultimate in portability.

› **PRESSURE:**  
5000 PSIG (345 BAR)

› **CHARGING RATE:**  
6 SCFM (170 L/MIN)

› **POWER:**  
6 HP (4.5 kW)

› **CONTRACT PERIOD:**  
09/25/22 - 09/24/27

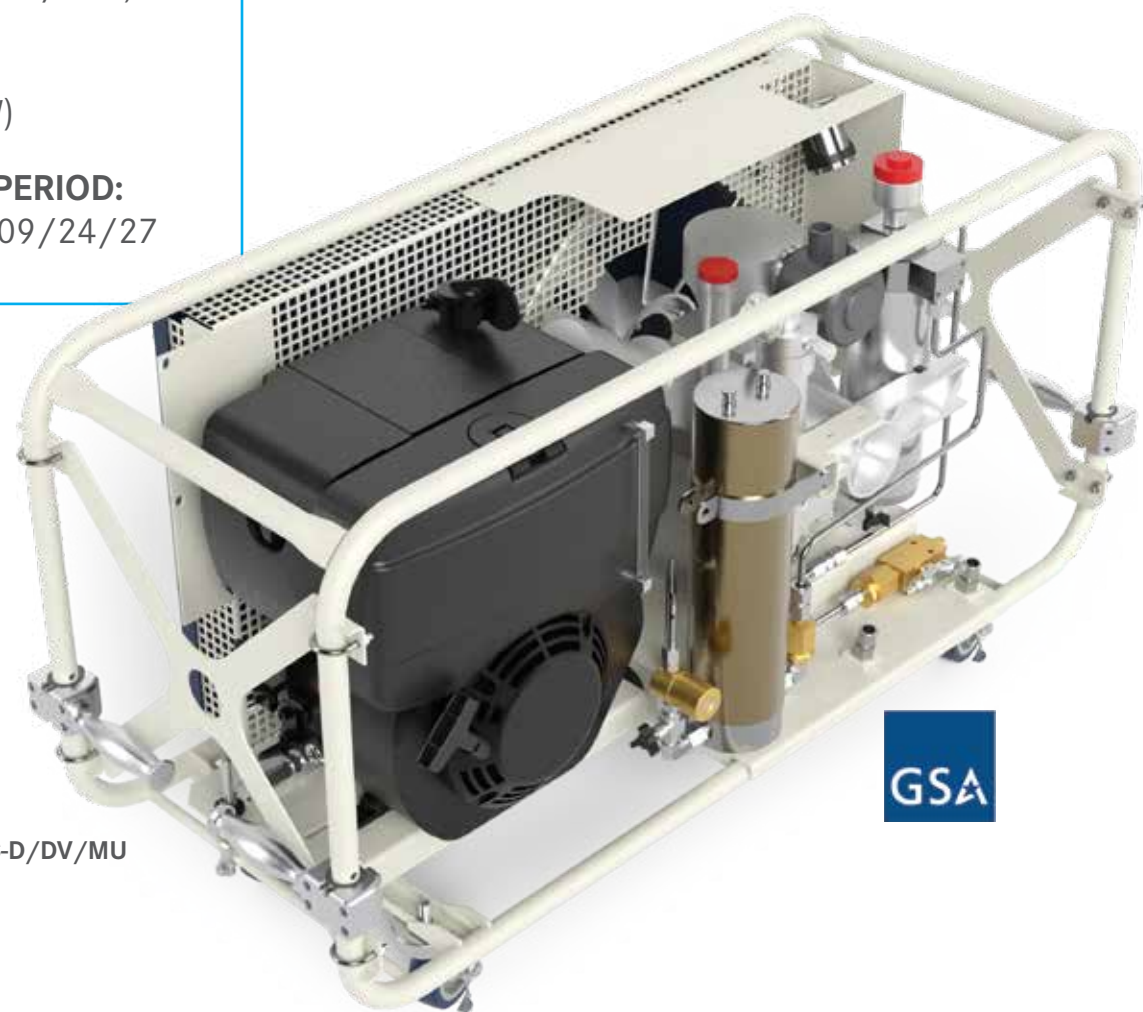

› C-D/DV/MU

## STANDARD SCOPE OF SUPPLY

- › Air-cooled high pressure CAPITANO compressor
- › Air-cooled diesel engine with 2.7 quart fuel tank
- › BAUER P1 breathing air purification system to process 15,000 CF of air per cartridge at standard inlet conditions (2 replacements)
- › Pressure maintaining valve
- › Check valve
- › Vent valve
- › Air outlet 1/4", with tee installed
- › Lightweight, tubular metal frame
- › Retractable carrying handles (4)
- › Heavy duty casters (4)
- › Hourmeter
- › Visual CO/moisture monitor indicator
- › Two 6 ft. fill hoses, each hose complete with shut-off valve, pressure gauge, vent valve and CGA-347 adapter C-D/DV/NAVY/SF (SCUBA)
- › Austenitic stainless steel tubing, tube fittings and fill hose fittings, high pressure instrument pipe fittings and anodized aluminum fill adapters
- › Inlet filter with 10 ft. flexible hose

## AVAILABLE ACCESSORIES

- › P1 purification cartridge
- › Certified air test with documentation
- › Intake filter
- › Fill hose assembly
- › Gasket, fill hose assembly, calibrated
- › Fill adapter

## SYSTEM FOOTPRINT

### DIMENSIONS L X W X H inches (mm)

- › 45.375" x 18.625" x 28.875" (1153mm x 473mm x 733mm)

### WEIGHT pounds (kg)

- › 262 lb (119 kg)

## TECHNICAL DATA

Model	Charging Rate <sup>1</sup>		Number of Stages	Motor		FAD <sup>2</sup>	RPM	Purification System
	SCFM	L/MIN		HP	kW			
<b>5000 PSIG (345 BAR)</b>								
C-D/DV/MU	6	170	3	6	4.5	5	1250	P1

1) Based on recharging an 80 cubic foot tank from 500 to 3000 psig. 2) Compressor capacity referenced to standard inlet conditions. Dimensions and weight are approximate and are subject to change.

A. BAUER COMPRESSOR warranty includes parts and labor 12 Months from date of compressor start-up or 18 Months from date of shipment.

B. Spare parts consisting of normal wear and tear items; e.g., replacement cartridges, valve overhaul kits, gasket kits, belt, oil, and inlet filter element, etc. are standard stock items at BAUER NORFOLK, BAUER SAN FRANCISCO, BAUER NORTHEAST.

# C-D/DV/MU/SS

(Available to all US Military, DOD and first responder customers)

## SCHEDULE MAS:

Total solutions for law enforcement, security, facilities management, fire, rescue, clothing, marine craft and emergency/disaster response.

**NAICS CODE #333912 | NSN: 4310-01-682-3829 | GSA CONTRACT: GS-07F-195GA**

Whether your requirement is filling an SCBA or SCUBA cylinder, look to the C-D/DV/MU/SS to fulfill your portable needs. A rugged stainless steel frame and optional cover assures all pressure bearing components are protected, even in the most severe conditions.

- › **PRESSURE:**  
5000 PSIG (345 BAR)
- › **CHARGING RATE:**  
6 SCFM (170 L/MIN)
- › **POWER:**  
6 HP (4.5 kW)
- › **CONTRACT PERIOD:**  
09/25/22 - 09/24/27

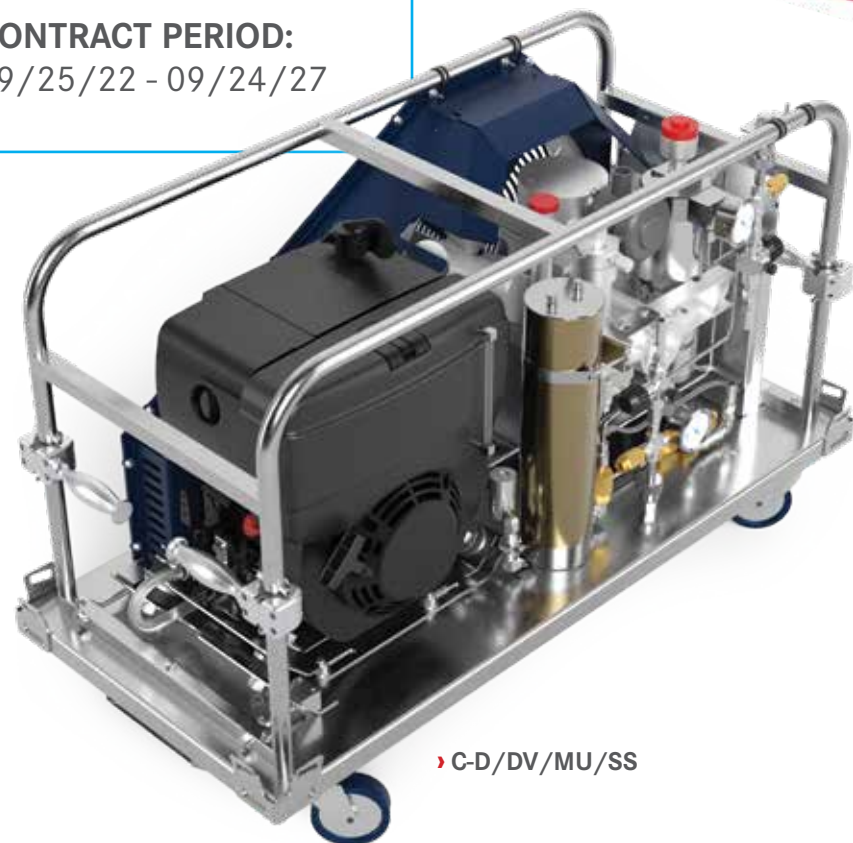

› C-D/DV/MU/SS

## STANDARD SCOPE OF SUPPLY

- › Air-cooled high pressure CAPITANO compressor
- › Marinized air-cooled diesel engine with 2.7 quart fuel tank (Muffler and throttle bracket nickel plated for corrosion inhibition)
- › BAUER P1 breathing air purification system to process 15,000 CF of air per cartridge at standard inlet conditions (2 replacements)
- › Pressure maintaining valve
- › Check valve
- › Vent valve
- › Air outlet 1/4", with tee installed
- › Visual CO/moisture monitor indicator
- › Two 6 ft. fill hoses, each hose complete with shut-off valve, pressure gauge, vent valve and CGA-347 adapter or C-D/DV/NAVY/SF (SCUBA)
- › Austenitic stainless steel tubing, tube fittings and fill hose fittings, high pressure instrument pipe fittings and anodized aluminum fill adapters
- › Inlet filter with 10 ft. flexible hose
- › Stainless steel: frame with integral skid plate, cover with retractable lifting handles and tie down points, cover latches and four-point mounted casters (brakes and are independently steerable)
- › Compressor and cover lifting handles (operator comfort)
- › Oil drain hoses for the compressor and diesel engine
- › Enhanced fill hose retainer attachment points
- › Metal interstage relief valve tagging

## AVAILABLE ACCESSORIES

- › P1 purification cartridge
- › Cover
- › Certified air test with documentation
- › Intake filter
- › Fill hose assembly
- › Gasket, fill hose assembly, calibrated
- › Fill adapter

## SYSTEM FOOTPRINT

- DIMENSIONS L X W X H inches (mm)**
- › 52" x 21.375" x 29" (1321mm x 543mm x 737mm)
- DRY WEIGHT pounds (kg)**
- › **Without cover:** 322 lb (146 kg)
  - › **Cover:** 64 lb (29 kg)
  - › **Total weight:** 386 lb (175 kg)

## TECHNICAL DATA

Model	Charging Rate <sup>1</sup>		Number of Stages	Motor		FAD <sup>2</sup>	RPM	Purification System
	SCFM	L/MIN		HP	kW			
<b>5000 PSIG (345 BAR)</b>								
C-D/DV/MU/SS	6	170	3	6	4.5	5	1250	P1

1) Based on recharging an 80 cubic foot tank from 500 to 3000 psig. 2) Compressor capacity referenced to standard inlet conditions. Dimensions and weight are approximate and are subject to change.\*

A. BAUER COMPRESSOR warranty includes parts and labor 12 Months from the date of compressor start-up or 18 Months from the date of shipment.

B. Spare parts consisting of normal wear and tear items, e.g., replacement cartridges, valve overhaul kits, gasket kits, belts, oil, and inlet filter element, etc., are standard stock items at BAUER NORFOLK, BAUER SAN FRANCISCO, and BAUER NORTHEAST.



# MII-D/DV

## SCHEDULE MAS:

Total solutions for law enforcement, security, facilities management, fire, rescue, clothing, marine craft and emergency/disaster response.

**NAICS CODE #333912 | NSN: 4310-01-500-9092 | GSA CONTRACT: GS-07F-195GA**

Want to accelerate filling an SCBA or SCUBA cylinder? Look to the MII-D/DV to fulfill your portable needs. Included are a high capacity 3-stage pressure lubricated compressor, an Arc Spray coated robust steel tubular frame, and a BAUER purification system.

- › **PRESSURE:**  
5000 PSIG (345 BAR)
- › **CHARGING RATE:**  
8.4 SCFM (238 L/MIN)
- › **POWER:**  
6.4 HP (4.8 kW)
- › **CONTRACT PERIOD:**  
09/25/22 - 09/24/27

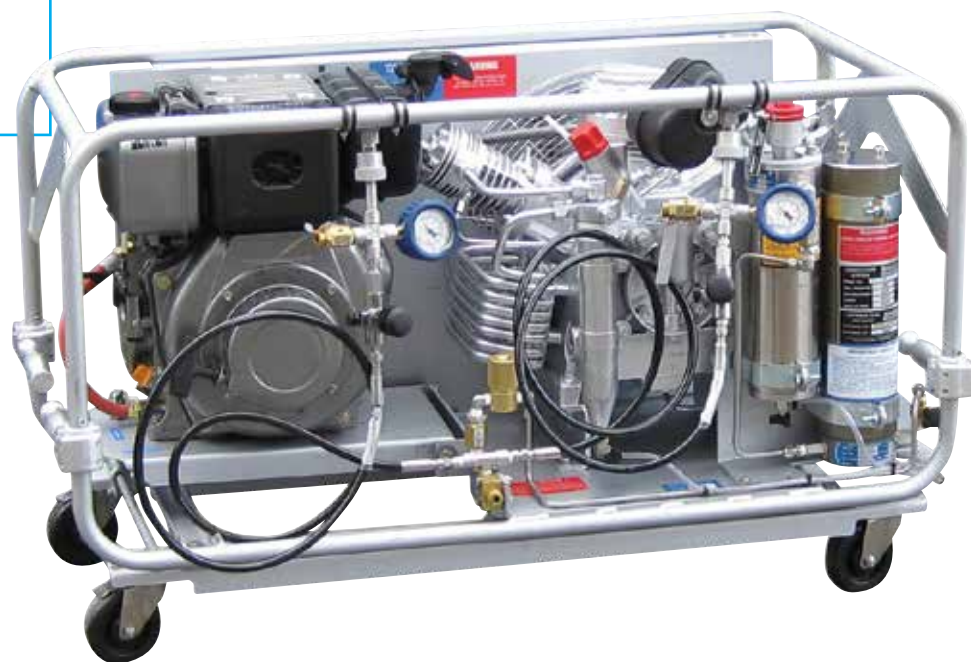

› MII-D/DV

## STANDARD SCOPE OF SUPPLY

- › Marinized air-cooled high pressure MARINER compressor
- › Marinized air-cooled diesel engine
- › BAUER P1 breathing air purification system to process 15,000 CF of air per cartridge at standard inlet conditions (2 replacements)
- › Pressure maintaining valve
- › Check valve
- › Vent valve
- › Air outlet 1/4", with tee installed
- › Lightweight, tubular metal frame
- › Retractable carrying handles (4)
- › Heavy duty casters (4)
- › Hourmeter
- › Visual CO/moisture monitor indicator
- › Two 6 ft. fill hoses, each hose complete with shut-off valve, pressure gauge, vent valve and CGA-347 adapter or C-D/DV/NAVY/SF (SCUBA)
- › Austenitic stainless steel tubing, tube fittings and fill hose fittings, high pressure instrument pipe fittings and anodized aluminum fill adapters
- › Inlet filter with 10 ft. flexible hose

## AVAILABLE ACCESSORIES

- › P1 purification cartridge
- › Certified air test with documentation
- › Intake filter
- › Fill hose assembly
- › Gasket, fill hose assembly, calibrated
- › Fill adapter
- › Compressor block heater
- › Diesel engine block heater
- › Package Hypalon® type cover

## SYSTEM FOOTPRINT

### DIMENSIONS L X W X H inches (mm)

- › 46.6875" x 22" x 27.875" (1186mm x 560mm x 708mm)

### WEIGHT pounds (kg)

- › 400 lb (181 kg)

## TECHNICAL DATA

Model	Charging Rate <sup>1</sup>		Number of Stages	Motor		FAD <sup>2</sup>	RPM	Purification System
	SCFM	L/MIN		HP	kW			
<b>5000 PSIG (345 BAR)</b>								
MII-D/DV	8.4	238	3	6.4	4.8	7	1250	P1

1) Based on recharging an 80 cubic foot tank from 500 to 3000 psig.

2) Compressor capacity referenced to standard inlet conditions. Dimensions and weight are approximate and are subject to change.

A. BAUER COMPRESSOR warranty includes parts and labor 12 Months from the date of compressor start-up or 18 Months from the date of shipment.

B. Spare parts consisting of normal wear and tear items, e.g., replacement cartridges, valve overhaul kits, gasket kits, belts, oil, inlet filter element, etc., are standard stock items at BAUER NORFOLK, BAUER SAN FRANCISCO, and BAUER NORTHEAST.

# DMT II

## 3- AND 4-STAGE HIGH-PRESSURE BREATHING AIR COMPRESSORS

We reinvented our BAUER DIVE MATE® product family for 2022. Introducing the new DMT II package. A combination of a high-strength aluminum alloy tubular frame and a formed motor baseplate create a durable foundation for this lightweight, yet robust, package. We have increased the number of compressor offerings and motor drives to allow you to tailor the package to your specific requirements. We challenge you to find a more flexible package or greater variety of amenities: from 8.4 to 13.0 scfm charge rate, three (3) or four (4) stage BAUER compressor and BAUER purification. Electric motor, gasoline, or diesel engine drives allow you to select the mode of power best suited to your specific requirements. Furthermore, we even offer two (2) trim levels to allow you to select the appropriate package, to meet the buyer's needs.

- › **PRESSURE:**  
Up to 6000 PSIG  
(414 BAR)
- › **CHARGING RATE:**  
8.4 to 13 SCFM  
(170 to 368 L/MIN)
- › **POWER:**  
7.5 to 14 HP  
(5.6 to 10.4 kW)



› DMT II



### STANDARD SCOPE OF SUPPLY

- › Available in three sizes 8, 10 & 13 SCFM charge rate
  - Choice of prime mover/drive
  - Electric motor, 1-phase or 3-phase
  - Gasoline engine (pull start)
  - Diesel engine (DMTII 08-DY & DMTII 10-DY, EPA Tier 4 Final, Pull start)
- › Inlet filter
- › Stainless steel intercoolers and aftercooler
- › High temperature switch (except D drive)
- › Vibration isolators
- › P31 Purification for 5000 PSIG systems
- › P41 Purification for 6000 PSIG systems
- › Low oil pressure switch (electric drive)
- › Motor starter with NEMA 4 enclosure (electric drive units)
- › Hourmeter (electric and gasoline drive) or Vibration type (diesel drive)
- › Final pressure switch (electric & gasoline drive)
- › Visual CO/moisture indicator
- › Lifting handles
- › Tubular aluminum frame

### DMT II ELITE (ADD TO ABOVE)

- › Interstage gauges
- › Automatic condensate drain
- › Electric start and low oil pressure switch for gasoline drive units.

### AVAILABLE ACCESSORIES (DEALER/CUSTOMER INSTALLED)

- › Wheel kit

### SYSTEM FOOTPRINT

#### DIMENSIONS L X W X H inches (mm)

- › 48" x 32" x 28" (1219mm x 819mm x 711mm)\*

#### WEIGHT pounds (kg)

- › 300 - 450 lb (136 - 204 kg)

\* Base Model

### AVAILABLE ACCESSORIES (FACTORY INSTALLED)

- › B-Timer (P31)

### TECHNICAL DATA

Model	Charging Rate <sup>1</sup>		Number of Stages	Motor		FAD <sup>2</sup>	Purification System
	SCFM	L/MIN		HP	kW		
<b>5000 PSIG (345 BAR)</b>							
DMTII 08-E1/E3	8.4	238	3	7.5	5.6	7	P31
DMTII 08-GK	8.4	238	3	14	10.4	7	P31
DMTII 08-DY	8.4	238	3	8.3	6.2	7	P31
<b>6000 PSIG (414 BAR)</b>							
DMTII 10-E1/E3	9.7	275	4	7.5	5.6	8.1	P41
DMTII 10-GK	9.7	275	4	14	10.4	8.1	P41
DMTII 10-DY	9.7	275	4	8.3	6.2	8.1	P41
DMTII 13-E1/E3	13	368	4	10	7.5	10.8	P41
DMTII 13-GK	13	368	4	14	10.4	10.8	P41

1) Based on recharging an 80 cubic foot tank from 500 to 3000 psig.

2) Compressor capacity referenced to standard inlet conditions.

E1= Single phase electric, 230 VAC/60 Hz. E3=Three phase electric, 208/230/460 VAC/60 Hz. Other voltages available on request. GK=Gasoline engine drive, KOHLER DY=Diesel engine drive, YANMAR. Dimensions and weight are approximate and are subject to change.

DIVE

DIVE



# VERTECON®

## 3-, 4-, AND 5-STAGE OPEN HIGH-PRESSURE BREATHING AIR COMPRESSORS

BAUER's VERTECON® series of high-pressure breathing air compressor systems have been an industry leader for many years. We combined the simplistic platform with an economical design, featuring the latest BAUER technological enhancements. The series now features an integral base that eliminates the guesswork of product placement, ensuring the system has been installed correctly for system ventilation and maintenance accessibility. With the advent of the integral base, the compressor package can also have a sound attenuated enclosure optionally installed at a later date. A refreshed HMI operations panel and electrical control system allow you to tailor the system to your specific requirements. When simple is what you want, look to BAUER.

- › **PRESSURE:**  
Up to 6000 PSIG (414 BAR)
- › **CHARGING RATE:**  
5 to 26.4 SCFM (142 to 748 L/MIN)
- › **POWER:**  
5 to 20 HP (3.7 to 15 kW)



› VERTECON

### STANDARD SCOPE OF SUPPLY

- › BAUER breathing air purification system
- › Open vertical cabinet made of formed sheet and plate goods provide a firm foundation for all pressure bearing components
- › Modern design with unsurpassed maintenance accessibility (no hand tools are required for normal maintenance checks and fluid level confirmation)
- › BAUER PLC based controller with 7" color HMI touchscreen display
- › Belt adjustment tool
- › NEMA 4 rated electrical enclosure with UL® listed control panel
- › All wiring harnesses incorporated within a corrugated loom with number coding for easy system diagnosis
- › Emergency stop push button
- › .049 wall thickness stainless steel tubing throughout; no cheap plastic tubing
- › Rugged powder coat finish
- › Zero loss automatic condensate drain system
- › Interstage pressure gauges (locally mounted)
- › Compressor on/off, final pressure, oil pressure and high-temperature shutdown
- › Motor overload indication
- › Final separator counter with shutdown and operator indication
- › Unique integrated positioning base which ensures correct installation every time

### TECHNICAL DATA

Model	Charging Rate <sup>1</sup>		Number of Stages	Motor		FAD <sup>2</sup>	RPM	Purification System
	SCFM	L/MIN		HP	kW			
<b>5000 PSIG (345 BAR)</b>								
VEC08-E1/E3	8.4	238	3	7.5	5.6	7	1250	P31
VEC20-E3	21	595	4	15	11	17.5	1300	P5
VEC26-E3	26.4	748	4	20	15	22	1350	P5
<b>6000 PSIG (414 BAR)</b>								
VEC05-E1/E3	5	142	3	5	3.7	4	1050	P2
VEC10-E1/E3	9.7	275	4	7.5	5.6	8.1	1180	P2
VEC13-E1/E3	13	368	4	10	7.5	10.8	1420	P2
VEC18-E3	18	510	4	15	11	15	1325	P5
VEC25-E3	25.2	714	5	20	15	21	1300	P5

1) Based on recharging an 80 cubic foot tank from 500 to 3000 psig.  
 2) Compressor capacity referenced to standard inlet conditions.  
 E1= Single phase electric, 230 VAC/60 Hz. E3=Three phase electric, 208/230/460 VAC/60 Hz. Other voltages available on request. Dimensions and weight are approximate and are subject to change.

### AVAILABLE ACCESSORIES (FACTORY INSTALLED)

- › BAUER Gas-Tek™ CO monitoring system
- › B-SECURUS - Electronic moisture monitoring for the purification system
- › B-Kool (floor mount only)
- › H<sub>2</sub>S monitoring system with audible alarm

### SYSTEM FOOTPRINT

- VEC05 - VEC13:**  
**DIMENSIONS L X W X H inches (mm)**  
 › 54" x 34" x 56" (1372.6mm x 863.6mm x 1422.4mm)  
**WEIGHT pounds (kg)**  
 › 800 - 900 lb (363 - 408.2 kg)
- VEC18 - VEC26:**  
**DIMENSIONS L X W X H inches (mm)**  
 › 54" x 34" x 63" (1372.6mm x 863.6mm x 1600.2mm)  
**WEIGHT pounds (kg)**  
 › 1200 - 1300 lb (544.3 - 589.7 kg)

DIVE FIRE

DIVE FIRE

# VERTICUS®

## 3-, 4-, AND 5-STAGE ENCLOSED HIGH-PRESSURE BREATHING AIR COMPRESSORS

The days of “Breadbox” designed compressor packages are over! Step up to the BAUER VERTICUS®. The updated, sound-attenuated cabinet is equipped with an aesthetically pleasing operations panel, ensuring easy access to the drive belts. Vertically hinged and lift-off side access doors incorporate fast pin technology for fast removal of the doors for maintenance – no hand tools required! The rear panel incorporates integral handles and a tabbed lift-off design. The front access door includes a hex-keyed latch to eliminate any accidental door openings while the system is operating. Sound attenuation has been incorporated on every possible panel to provide a nice and quiet operating level of approximately 72 dB (within one meter). One package size accommodates BAUER high-pressure air-cooled compressors from 5 to 20 Hp motors. Our new, larger, 7” HMI enhances the monitoring of system functions.

- › **PRESSURE:**  
Up to 6000 PSIG (414 BAR)
- › **CHARGING RATE:**  
5 to 26.4 SCFM (142 to 748 L/MIN)
- › **POWER:**  
5 to 20 HP (3.7 to 15 kW)



› VERTICUS

### STANDARD SCOPE OF SUPPLY

- › BAUER breathing air purification system with B-SECURUS
- › BAUER PLC based controller with 7” color HMI touchscreen display
- › NEMA 4 rated electrical enclosure with UL® listed control panel
- › Compressor low oil pressure and high-temperature safety shutdowns
- › Emergency stop push button and automatic start/stop control
- › Zero loss automatic condensate drain system with non-corrosive condensate reservoir and integrated float sensor and automatic “Full” indication and compressor shutdown
- › Interstage pressure gauges (locally mounted)
- › Vertically hinged front operations panel and lift-off side maintenance access doors
- › Inlet filter maintenance indicator
- › Unique hinged front operations panel

### AVAILABLE ACCESSORIES (FACTORY INSTALLED)

- › BAUER Gas-Tek™ CO monitoring system
- › B-Kool
- › H<sub>2</sub>S monitoring system with audible alarm

### SYSTEM FOOTPRINT

- VERTICUS:**  
**VAC5 - VAC26**  
**DIMENSIONS L X W X H inches (mm)**  
 › 55” x 35” x 70” (1397mm x 737mm x 1778mm)  
**WEIGHT pounds (kg)**  
 › 1000 - 1400 lb (453.6 - 635 kg)

### TECHNICAL DATA

Model	Charging Rate <sup>1</sup>		Number of Stages	Motor		FAD <sup>2</sup>	RPM	Purification System
	SCFM	L/MIN		HP	kW			
<b>5000 PSIG (345 BAR)</b>								
VAC20-E3	2.1	595	4	15	11	17.5	1300	P5 B-SECURUS
VAC26-E3	26.4	748	4	20	15	22	1350	P5 B-SECURUS
<b>6000 PSIG (414 BAR)</b>								
VAC5-E1/E3	5	142	3	5	3.7	4	1050	P2 B-SECURUS
VAC08-E-1/E3	8	227	3	7.5	5.6	7	1450	P2 B-SECURUS
VAC10-E1/E3	9.7	275	4	7.5	5.6	8.1	1180	P2 B-SECURUS
VAC13-E1/E3	13	368	4	10	7.5	10.8	1420	P2 B-SECURUS
VAC18-E3	18	510	4	15	11	15	1325	P5 B-SECURUS
VAC25-E3	25.2	714	5	20	15	21	1300	P5 B-SECURUS

1) Based on recharging an 80 cubic foot tank from 500 to 3000 psig.  
 2) Compressor capacity referenced to standard inlet conditions.  
 3) 30 HP units are in a cabinet other than depicted.  
 E1= Single phase electric, 230 VAC/60 Hz. E3=Three phase electric, 208/230/460 VAC/60 Hz. Other voltages available on request. Dimensions and weight are approximate and are subject to change.

DIVE FIRE

DIVE FIRE



# 7000 PSIG Breathing Air Systems



FIRE

## 7000 PSIG HIGH-PRESSURE BREATHING AIR COMPRESSORS SYSTEMS

As SCBA working pressures increase, so must the fire department's high-pressure breathing air compressor system. If left unchecked, the department runs the risk of not supporting their breathing air demand for grade "E" breathing air. BAUER Compressors is the first company in the industry to offer a wide and varied product portfolio to meet your specific needs. We start with a performance-proven BAUER air-cooled high-pressure compressor designed, built, and rated for continuous duty operations at 7000 PSIG. The compressor has been in existence long before others. It has proven itself since 1992 in the high-pressure, non-breathing air market where up-time demands are far more stringent than the breathing air market. We couple the compressor to one of our BAUER high-pressure breathing air purification systems, designed for continuous operations at 7000 PSIG while meeting the Compressed Gas Association's rigorous breathing air quality standards for grade "E" air and/or the National Fire Protection Association (1989 standard for high-pressure breathing air) along with many other recognized global standards.

BAUER Compressors offers two (2) models of 7000 PSIG compressor packages, each outfitted to meet your specific requirements. A simplistic component system utilizing one of our VERTECON® compressor packages. Along with an independently tested and verified CFS5.5®-3S or CFS5.5®-2S SCBA containment fill station and an ASME coded air storage system; Or step up to either a UNICUS® 4S or UNICUS® 4i All-In-One compressor package, each outfitted to meet your specific needs. No matter which compressor system you select, rest assured all of the components were chosen in strict adherence to NFPA 1901-2016 edition, calling for a 4:1 structural safety factor.

### VERTECON® STANDARD SCOPE OF SUPPLY

- › BAUER breathing air purification system
- › Open vertical cabinet made of formed sheet steel providing a firm foundation for all pressure bearing components
- › Modern design with unsurpassed maintenance accessibility (no hand tools are required for normal maintenance checks and fluid level confirmation)
- › BAUER PLC based controller with 7" color HMI touchscreen display
- › Self-adjusting drive belt tensioner
- › NEMA 4 rated electrical enclosure with UL® listed control panel
- › All wiring harnesses incorporated within a corrugated loom with number coding for easy system diagnosis
- › Emergency stop push button
- › Stainless steel tubing throughout, no cheap plastic tubing
- › Rugged powder coat finish
- › Automatic condensate drain system with integral reservoir level sensor to provide system shutdown when the reservoir is full
- › Interstage pressure gauges (locally mounted)
- › SECURUS Moisture Monitor

### SYSTEM FOOTPRINT

**DIMENSIONS L X W X H inches (mm)**

- › 54" x 34" x 63" (1372mm x 864mm x 1600mm)

**WEIGHT pounds (kg)**

- › 1075 lb (488 kg)

### PLC CONTROLLER

- › Compressor on/off, final pressure, oil pressure, high temperature shutdown
- › Supports automatic condensate drain system
- › Motor overload indication
- › Final separator counter with shutdown and operator indication

### TECHINICAL DATA

Model	Block	Charging Rate <sup>1</sup>		Number of Stages	Motor		FAD <sup>2</sup>	RPM	Purification System
		SCFM	L/MIN		HP	kW			
<b>7000 PSIG (476 BAR)</b>									
VTC-7K/20	IK18.11I	20	566	5	20	15	17	1300	P5 B-SECURUS
VTC-7K/15	IK15.11	13	368	4	15	11	11	960	P5 B-SECURUS

1) Based on recharging an 80 cubic foot tank from 500 to 3000 psig. 2) Compressor capacity referenced to standard inlet conditions. E3=Three phase electric, 208/230/460 VAC/60 Hz. Other voltages available on request.



FIRE

### AVAILABLE ACCESSORIES (FACTORY INSTALLED)

- › BAUER Gas-Tek™ CO monitoring system
- › H<sub>2</sub>S monitoring system



› CFS5.5®-2S



› CFS5.5®-3S

## CFS5.5®

### STANDARD SCOPE OF SUPPLY

- › Complete with SCBA fill connection, fill hose and bleed valve
- › Fill control panel with an adjustable regulator, relief valve, manual control valve and pressure gauge for each fill position
- › Convenient door handle actuation, bottom venting and reduced footprint
- › Hands-free door interlock
- › Compliant with NFPA 1901 2016 Edition
- › Four bank dual function cascade controls
- › Air direction valve

### SYSTEM FOOTPRINT

#### CFS5.5®-3S

##### DIMENSIONS L X W X H inches (mm)

- › 41" x 21" x 57" (1041mm x 533mm x 1448mm)

##### WEIGHT pounds (kg)

- › 1000 lb (454 kg)

#### CFS5.5®-2S

##### DIMENSIONS L X W X H inches (mm)

- › 30" x 21" x 57" (762mm x 533mm x 1448mm)

##### WEIGHT pounds (kg)

- › 750 lb (390.2 kg)

### TECHINICAL DATA

Model	Description
CFS5.5®-2S	Two position CFS equipped with inlet pressure gauge adjustable regulator, regulated pressure gauge, fill control valve and fill pressure gauges. Unit will consist of Dual function, top mount, four bank cascade panel. The dual function feature offers the ability to refill a storage bank, even with the bank valve closed, while filling SCBA's from another bank. It also includes an air direction valve allowing the operator to select "fill from storage" or "fill from compressor", additionally the system includes a regulated remote fill outlet.
CFS5.5®-3S	Three position CFS equipped with inlet pressure gauge adjustable regulator, regulated pressure gauge, fill control valve and fill pressure gauges. Unit will consist of Dual function, top mount, four bank cascade panel. The dual function feature offers the ability to refill a storage bank, even with the bank valve closed, while filling SCBA's from another bank. It also includes an air direction valve allowing the operator to select "fill from storage" or "fill from compressor", additionally the system includes a regulated remote fill outlet.

## AIR STORAGE STANDARD SCOPE OF SUPPLY

- › The scope of supply for the ASME cylinder assembly includes four ASME coded cylinders, an ASME safety relief valve, cylinder valve and drain valve for each cylinder
- › Assemblies are designed to be used with a BAUER four-bank cascade panel. Gauges are not included on the individual cylinders as they are on the cascade pane.
- › ASME-7K-3:1 is a heavy-duty, welded steel rack designed for vertical cylinder configuration for stationary or mobile applications. Each cylinder is independently affixed to the rack with unistrut type clamps
- › ASME-7K-4:1 is a heavy-duty, welded steel rack designed for horizontal cylinder configuration for stationary applications. Each cylinder is independently affixed to the rack with clamps

### SYSTEM FOOTPRINT

#### ASME-7K-3

##### DIMENSIONS L X W X H inches (mm)

- › 52" x 17.5" x 69.5" (1320.8mm x 444.5mm x 1765.3mm)

##### WEIGHT pounds (kg)

- › 2000 lb (3220 kg)

#### ASME-7K-4

##### DIMENSIONS L X W X H inches (mm)

- › 95" x 34" x 44" (2413mm x 864mm x 1118mm)

##### WEIGHT pounds (kg)

- › 7100 lb (3220 kg)



› ASME-7K-3:1

### TECHINICAL DATA

Model	Description
ASME - 7K-3:1	4 Cylinder System with maximum operating pressure of 7000 PSIG installed in a vertical rack. System shall provide a 3:1 structural safety factor
ASME - 7K-4:1	4 Cylinder System with maximum operating pressure of 7000 PSIG installed in a horizontal rack. System shall provide a 4:1 structural safety factor

FIRE

FIRE



## 7000 PSIG ALL IN ONE SYSTEM: UNICUS® 4S & 4i

BAUER COMPRESSORS, INC. is the first company to offer a fully unitized compressor system built for 7000 PSIG service. Let's start with continuous duty BAUER 7000 PSIG compressors, which were in existence well before others put pen to paper. We couple the compressor to a BAUER high pressure breathing air purification system that meets the rigorous CGA, NFPA, and many other global standards for high pressure breathing air. A sound attenuated cabinet enclosure incorporates a four (4) cylinder 7000 PSI ASME air storage system along with an NFPA compliant 3-position containment SCBA fill station. Operations and systems functions are simplified with everything located on a centrally located and illuminated operations panel, including an ergonomic and intuitive HMI touchscreen.

Additionally, we are offering you two (2) modes of operation, analog or automatic. The UNICUS® 4S is your choice for all things manually controlled. Should your department wish the automated path, select the UNICUS® 4i. If you want to dress your unit in concert with the Fire Departments theme, ask about our Fire Edition package. Look to BAUER COMPRESSORS when your department needs the best all-in-one compressor system on the market today, backed by our global network of service partners.

FIRE

- › **PRESSURE:**  
Up to 7000 PSIG  
(483 BAR)
- › **CHARGING RATE:**  
13 to 20 SCFM  
(368 to 566 L/MIN)
- › **POWER:**  
15 to 20 HP  
(11 to 15 kW)



› UNICUS® 4i



OPTIONAL

**UNICUS® 4i  
FIRE EDITION**  
OPTIONAL FIRE EDITION PAINT SCHEME  
(SHOWN HERE)

## STANDARD SCOPE OF SUPPLY

- › BAUER breathing air purification system with B-SECURUS
- › BAUER PLC based controller with 7" color HMI touchscreen display on 4S; 15" HMI on 4i
- › NEMA 4 rated electrical enclosure with UL® listed control panel
- › Compressor low oil pressure and high temperature safety shutdowns
- › Emergency stop push button
- › Hinged cascade fill control panel with Lexan laminate air flow/fill schematic
- › Audible alarm on safety shutdowns
- › Inlet filter maintenance indicator
- › Automatic condensate drain system with non-corrosive condensate reservoir and integrated float sensor and automatic "Full" indication and compressor shutdown
- › Four (4) ASME 7000 PSI code stamped air cylinders; Cylinders are rated with a 3:1 SF
- › Sound attenuating enclosure with slam-action latches and lift-off type hinges
- › NFPA 1901 2016 edition compliant 3 position containment fill station accommodates SCBA or SCUBA cylinders up to 31" overall length
- › Manually controlled dual-function 4 bank cascade controls with air direction valve are standard on the 4S models; Automatic cascade controlled logic is standard on the 4i models

## AVAILABLE ACCESSORIES (FACTORY INSTALLED)

- › BAUER Gas-Tek™ CO monitoring system
- › BAUER RFIDPro™ SCBA data logging (UNICUS 4S)
- › RFID data tags (UNICUS 4i & UNICUS 4S)
- › RFID SCBA data logging intergrated into fill station (UNICUS 4i)
- › 100 ft high-pressure cabinet enclosed hose reel
- › Panel mounted remote fill hose connection
- › Dual Fill-all SCBA positions
- › Tri Fill-all SCBA positions

## SYSTEM FOOTPRINT

### DIMENSIONS L x W x H inches (mm)

- › 101" x 38" x 80" (2565mm x 965mm x 2032mm)

### WEIGHT pounds (kg)

- › 4350 - 4550 lb (1973 - 2064 kg)

## TECHNICAL DATA

Model	Charging Rate <sup>1</sup>		Number of Stages	Motor		FAD <sup>2</sup>	RPM	Purification System
	SCFM	L/MIN		HP	kW			
<b>7000 PSIG (483 BAR)</b>								
UN 4S-15/7K	13	368	4	15	11	10.8	960	P5 B-SECURUS
UN 4S-20/7K	20	566	5	20	15	17	1300	P5 B-SECURUS
UN 4i-15/7K	13	368	4	15	11	10.8	960	P5 B-SECURUS
UN 4i-20/7K	20	566	5	20	15	17	1300	P5 B-SECURUS

1) Based on recharging an 80 cubic foot tank from 500 to 3000 psig. 2) Compressor capacity referenced to standard inlet conditions. E3=Three phase electric, 208/230/460 VAC/60 Hz. Other voltages available on request. Dimensions and weight are approximate and are subject to change.

## OPTIONAL ACCESSORIES - 7000 SERIES UNICUS 4S & UNICUS 4I

Item	Description	
0001	BAUER Gas-Tek™ Electronic carbon monoxide monitor complete with calibration kit wired for alarm and shutdown. (calibration gas included)	GT/CO/III
0002	Panel mounted remote fill hose connection. Includes bulkhead fitting, adjustable regulator for up to 6000 PSIG service, gauge, isolation valve and quick connect/disconnect fitting (hose no included)	/RF/REG
0003	UN4 remote fill hose connection including adjustable regulator for up to 6000 PSIG service, gauge and isolation valve connected to a cabinet enclosed hose reel with 100 feet of hose rated for 6000 PSIG service	UN4/RF/REL-9
0004	DUAL-FILL, high/low, quick connect fill system (specify fill pressures)	DUAL-FILL/3 position
0005	TRI-FILL, high/low/SCUBA, quick connect fill system (specify fill pressures)	TRI-FILL/3 position
0006	Fire Edition paint scheme	
<b>FOR UNICUS® 4i ONLY</b>		
0007	RFID SCBA Data Logging	RFID4i
0008	RFID DATA TAGS Each Kit includes 25-each tags	KIT-0557

FIRE

# PLUS MODULE

## 3- AND 4-STAGE MULTI-FUNCTIONAL HIGH-PRESSURE BREATHING AIR COMPRESSORS VERTICUS PLUS®

The same package amenities found in the VERTICUS® high pressure breathing air compressor system, plus a free-standing aesthetically pleasing multi-functional fill station module, are combined to create the BAUER VERTICUS PLUS®. BAUER's performance-proven CFS5.5®-2S NFPA compliant containment fill station; two (2) bank dual function cascade controls; integral air storage rack with two (2) UN/ISO code air storage cylinders; 3-way selector valve to select either air from the compressor or onboard air storage system all come together creating the ultimate fill station. Install the two (2) modules side by side as an all-in-one configuration or apart based on the installation site specifics. Flexibility is the key; look to BAUER to unlock the possibilities.

### › CONFIGURATION 1

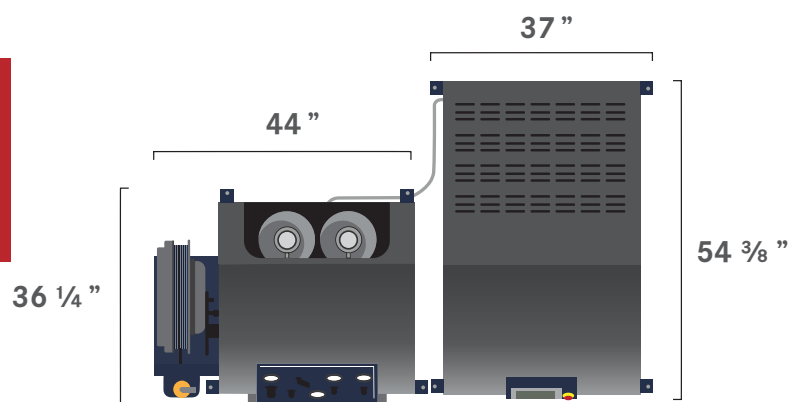

Fill station module showing optional hose reel

### › CONFIGURATION 2

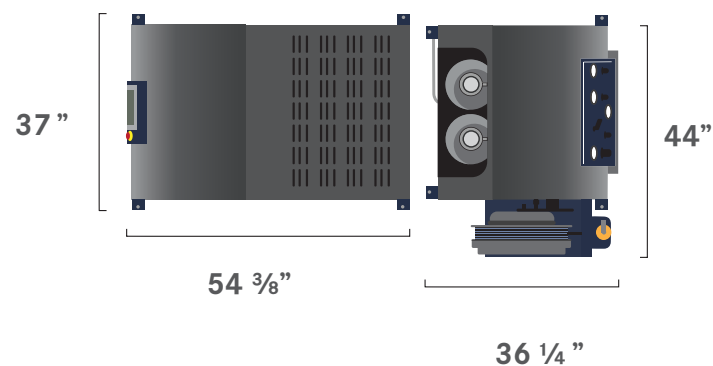

Fill station module showing optional hose reel

## NOW AVAILABLE IN TWO NEW EXCITING OFFERINGS!

### VERTECON® PLUS

BAUER's series of high-pressure breathing air compressor systems have been an industry leader for many years. An economical design featuring the latest BAUER technological enhancements and unsurpassed maintenance accessibility is incorporated within the simplistic platform. The series now features an integral base that eliminates the guesswork of product placement, ensuring the system has been installed correctly for system ventilation and maintenance accessibility.

Matched with the VERTECON® Compressor is the CFS5.5®-2/PLUS: A two-position Fully NFPA Compliant (1901 & 1989) SCBA/SCUBA Fill Station. The CFS5.5®-2/PLUS includes an attractive, ergonomically designed, two-bank Cascade Fill Control Panel and an integral air storage system consisting of two 6000 PSIG UN/ISO air storage cylinders. The VERTECON® PLUS System can be further enhanced by the substitution of ASME air storage cylinders in lieu of UN and the addition of the optional Regulated Remote Fill Outlet, including a high-pressure hose reel and 100 ft. of 6000 PSIG High-Pressure Hose!



Fill station module showing optional hose reel

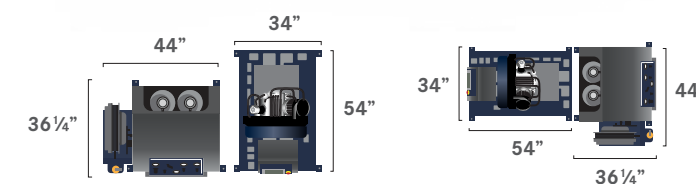

### › CONFIGURATION 1

### › CONFIGURATION 2

### BAUER LEGACY® PLUS

The BAUER LEGACY™ Series built in the rugged and proven VERTECON® Frame offers "Back To Basics Simplicity" while still incorporating PLC Control! Replacing the HMI/Touchscreen will be a simple, illuminated On/ Off Switch and a set of flashing indicator lamps; the lamps will flash a code representing fault warnings and shutdowns.

Matched with the BAUER LEGACY™ Compressor is the CFS5.5®-2/PLUS: A two-position Fully NFPA Compliant (1901 & 1989) SCBA/SCUBA Fill Station. The CFS5.5®-2/PLUS includes an attractive, ergonomically designed, two-bank Cascade Fill Control Panel and an integral air storage system consisting of two 6000 PSIG UN/ISO air storage cylinders. The BAUER LEGACY™ System can be further enhanced by the substitution of ASME air storage cylinders in lieu of UN/ISO and the addition of the optional Regulated Remote Fill Outlet including a high-pressure hose reel and 100 ft. of 6000 PSIG High-Pressure Hose!



Fill station module showing optional hose reel

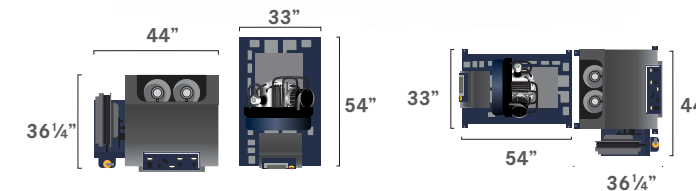

### › CONFIGURATION 1

### › CONFIGURATION 2

FIRE

FIRE



# UNICUS® 4S

## 4- AND 5-STAGE ALL-IN-ONE HIGH-PRESSURE BREATHING AIR COMPRESSORS

A modern upgrade with the simplicity of analog controls; Aesthetically pleasing yet robust design found only in the UNICUS® 4S All-In-One platform. The system is available in either 5000 or 6000 PSIG with discharge capacities ranging from 13 SCFM charge rate to 26 SCFM charge rate. Unsurpassed maintenance accessibility abounds as we have provided all access doors with snap pin technology – pull the pin and lift the door; no hand tools are required. Should you require access to the back of the operations panel, no problem; we have your back, the panel tilts forward. All requisite panels are equipped with sound attenuated material. An integral rack built to accommodate four (4) storage cylinders is standard, along with the piping. Additionally, we provide two (2) ASME-coded air storage cylinders as a part of the standard scope of supply. If you want to dress your unit up in concert with the Fire Department theme, ask about our Fire Edition package. When your department needs the best All-In-One compressor system on the market today and backed by our global network of service partners, look to BAUER.

- › **PRESSURE:**  
Up to 6000 PSIG (414 BAR)
- › **CHARGING RATE:**  
13 to 26.4 SCFM (368 to 748 L/MIN)
- › **POWER:**  
10 to 20 HP (7.5 to 15 kW)



**UNICUS® 4S  
FIRE EDITION**  
OPTIONAL FIRE EDITION PAINT SCHEME (SHOWN HERE)

### STANDARD SCOPE OF SUPPLY

- › BAUER breathing air purification system with B-SECURUS
- › BAUER PLC based controller with 7” color HMI touchscreen display
- › NEMA 4 rated electrical enclosure with UL® listed control panel
- › Compressor low oil pressure and high temperature safety shutdowns
- › Emergency stop push button
- › Hinged cascade fill control panel with Lexan laminate air flow/fill schematic
- › Audible alarm on safety shutdowns
- › Inlet filter maintenance indicator
- › Automatic condensate drain system with non-corrosive condensate reservoir and integrated float sensor and automatic “Full” indication and compressor shutdown
- › Two (2) ASME code stamped air cylinders installed in an integral rack designed to hold four cylinders
- › Sound attenuating enclosure with slam-action latches and lift-off type hinges
- › NFPA 1901 2016 edition compliant 3 position containment fill station accommodates SCBA or SCUBA cylinders up to 31” overall length

### SYSTEM FOOTPRINT

**UN 4S/13H-E1/E3 - UN 4S/26-E3:**  
**DIMENSIONS L X W X H inches (mm)**  
 › 101” x 38” x 80” (2565mm x 965mm x 2032mm)  
**WEIGHT pounds (kg)**  
 › 4350 - 4550 lb (1973 - 2064 kg)

### AVAILABLE ACCESSORIES (FACTORY INSTALLED)

- › BAUER Gas-Tek™ CO monitoring system
- › 100 ft high pressure cabinet enclosed hose reel
- › Panel mounted remote fill hose connection
- › Dual Fill/3 position
- › Tri Fill/3 position

### TECHNICAL DATA

Model	Charging Rate <sup>1</sup>		Number of Stages	Motor		FAD <sup>2</sup>	RPM	Purification System
	SCFM	L/MIN		HP	kW			
<b>5000 PSIG (345 BAR)</b>								
UN 4S/20-E3	21	595	4	15	11	17.5	1300	P5 B-SECURUS
UN 4S/26-E3	26.4	748	4	20	15	22	1350	P5 B-SECURUS
<b>6000 PSIG (414 BAR)</b>								
UN 4S/13H-E1/E3	13	368	4	10	7.5	10.8	1420	P2 B-SECURUS
UN 4S/18H-E3	18	510	4	15	11	15	1325	P5 B-SECURUS
UN 4S/25H-E3	25.2	714	5	20	15	21	1300	P5 B-SECURUS

1) Based on recharging an 80 cubic foot tank from 500 to 3000 psig.  
 2) Compressor capacity referenced to standard inlet conditions.  
 E1=Single phase electric, 230 VAC/60 Hz. E3=Three phase electric, 208/230/460 VAC/60 Hz. Other voltages available on request. Dimensions and weight are approximate and are subject to change.

### OPTIONAL ACCESSORIES

Item	Description	Part Number
0001	BAUER Gas-Tek™ Electronic carbon monoxide monitor complete with calibration kit wired for alarm and shutdown. (calibration gas included)	GT/CO/III
0002	Each additional ASME 5000 PSIG cylinder with relief valve and mounting clamps	/CYL-9/5K
0003	Each additional ASME 6000 PSIG cylinder with relief valve and mounting clamps	/CYL-9/6K
0003	Panel mounted remote fill hose connection. Includes bulkhead fitting, adjustable regulator for up to 6000 PSIG service, gauge, isolation valve and quick connect/disconnect fitting (hose no included)	/RF/REG
0004	UN4 remote fill hose connection including adjustable regulator for up to 6000 PSIG service, gauge and isolation valve connected to a cabinet enclosed hose reel with 100 feet of hose rated for 6000 PSIG service	UN4/RF/REL-12
0005	DUAL-FILL, high/low, quick connect fill system (specify fill pressures)	DUAL-FILL/3 position
0006	TRI-FILL, high/low/SCUBA, quick connect fill system (specify fill pressures)	TRI-FILL/3 position
0007	Fire Edition paint scheme	

FIRE

OPTIONAL

# INNOVATION AT YOUR FINGERTIPS



# NEWLY REDESIGNED



- Motor ratings from 10 to 20 hp
- Discharge capacity from 13 to 26.4 scfm charge rate
- Industrial grade 15"-HMI/Interactive Touchscreen
- Operational pressures from 5000 to 7000 psig

## INCREASED UPTIME QUICKER AND SECURE ACCESS

Our auto cascade system has replaced all operations panel-mounted valves and pressure gauges which help reduce human error when filling SCBA and SCUBA cylinders.

All system controls are within the panel-mounted HMI and include:

- › Airstorage controls
- › Independent SCBA fill pressures
- › Independent SCBA fill speed
- › Automatic cascade control system rated for 7000 psi service
- › Secure and quicker way to log into the unit with a BAUER key fob

Manual cascade bypass control comes standard to fill cylinders in case of a system power loss.

Optional Features:

- › RFID Reader interface, automatically read & records the SCBA fill event in accordance with NFPA 1989 data collection requirements
- › Gas-Tek monitoring systems allow you to tailor the system to your departments specific requirements



# UNICUS® 4i

## 4- AND 5-STAGE HIGH-PRESSURE BREATHING AIR COMPRESSORS

This game-changing filling station employs our state-of-the-art control system centered around a 15-inch HMI touch screen interface, which allows the operator to manage the entire system from the single-point touch screen. UNICUS®4i has several innovative optional features including BAUER Gas-Tek™ monitoring system, and RFID Reader.

- › **PRESSURE:**  
Up to 6000 PSIG  
(414 BAR)
- › **CHARGING RATE:**  
13 to 26.4 SCFM  
(368 to 748 L/MIN)
- › **POWER:**  
10 to 20 HP  
(7.5 to 15 kW)



› UNICUS® 4i



› UNICUS® 4i  
(SHOWING INSIDE FRONT)



› UNICUS® 4i  
(SHOWING INSIDE BACK)

### STANDARD SCOPE OF SUPPLY

- › BAUER breathing air purification system with B-SECURUS
- › **BAUER 15-inch HMI touch-screen** interface
- › Solid state auto cascade system
- › Compressor low oil pressure and high temperature safety shutdowns
- › Emergency stop push button
- › Ergonomic system-operations panel
- › Ergonomically designed stainless steel fill adaptors with integral bleed valve
- › Automatic condensate drain system with non-corrosive condensate reservoir and integrated float sensor and automatic “Full” indication and compressor shutdown
- › Two (2) ASME code stamped air cylinders installed in an integral rack designed to hold four cylinders
- › NFPA 1901 2016 edition compliant 3 position containment fill station accommodates SCBA or SCUBA cylinders up to 31” overall length

### TECHNICAL DATA

Model	Charging Rate <sup>1</sup>		Number of Stages	Motor		FAD <sup>2</sup>	Purification System
	SCFM	L/MIN		HP	kW		
<b>5000 PSIG (345 BAR)</b>							
UNICUS 4i -26 - E3	26.4	748	4	20	15	22	P5 B-SECURUS
UNICUS 4i -20 - E3	21	595	4	15	11	17.5	P5 B-SECURUS
<b>6000 PSIG (414 BAR)</b>							
UNICUS 4i -13- E1/E3	13	368	4	10	7.5	10.8	P2 B-SECURUS
UNICUS 4i -18- E3	18	510	4	15	11	15	P5 B-SECURUS
UNICUS 4i -25- E3	25.2	714	5	20	15	21	P5 B-SECURUS

1) Based on recharging an 80 cubic foot tank from 500 to 3000 psig.  
2) Compressor capacity referenced to standard inlet conditions. Tolerance +/- 5%

### SYSTEM FOOTPRINT

- DIMENSIONS L x W x H inches (mm)**
- › 101” x 38” x 80” (2565mm x 965mm x 2032mm)
- WEIGHT pounds (kg)**
- › 4350 - 4550 lb (1973 - 2064 kg)
- \*Weights are based on a unit equipped with 4 ASMEs

### AVAILABLE ACCESSORIES (FACTORY INSTALLED)

- › **BAUER Gas-Tek™** CO monitoring system
- › **RFID Reader** which reads and records data from the RFID equipped cylinders
- › Hose reel for 100’ of high pressure breathing air hose
- › Reg/RF
- › Dual Fill/3 position
- › Tri Fill/3 position

### OPTIONAL ACCESSORIES

Item	Description	Part Number
0001	BAUER Gas-Tek™ electronic carbon monoxide monitor complete with calibration kit wired for alarm and shutdown. (calibration gas included)	GT/CO/III
0002	Each additional ASME 5000 PSIG cylinder with relief valve and mounting clamps	/CYL-9/5K
0003	Each additional ASME 6000 PSIG cylinder with relief valve and mounting clamps	/CYL-9/6K
0004	Panel mounted remote fill hose connection. Includes bulkhead fitting, adjustable regulator for up to 6000 PSIG service, gauge, isolation valve and quick connect/disconnect fitting (hose no included)	/RF/REG
0005	UN4 remote fill hose connection including adjustable regulator for up to 6000 PSIG service, gauge and isolation valve connected to a cabinet enclosed hose reel with 100 feet of hose rated for 6000 PSIG service	UN4/RF/REL-12
0006	DUAL-FILL, high/low, quick connect fill system (specify fill pressures)	DUAL-FILL/3 position
0007	TRI-FILL, high/low/SCUBA, quick connect fill system (specify fill pressures)	TRI-FILL/3 position
0008	Fire Edition paint scheme	
<b>FOR UNICUS® 4i ONLY</b>		
0009	RFID SCBA Data Logging	RFID4i
0010	RFID DATA TAGS Each Kit includes 25-each tags	KIT-0557
0011	Cloud Storage for RFIDPro® SCBA cylinder management system. Price based upon number of SCBA's	TBD

FIRE

# 0320-E/D

## 4-STAGE HIGH PRESSURE BREATHING AIR COMPRESSORS

The 0320-E/D series of compressors are your solution for onshore and offshore applications when an efficient compressor is required for the budget consciousness oil and gas market. Corrosion resistant components, which are assembled and tubed with stainless steel fasteners and fittings, make the 0320-E/D an ideal choice when a robust compressor is required for the extremes of the drilling environment. Enhanced purification and diesel engine upgrades allow us to have third party certification for operations at temperatures up to 55°C (131°F).



› 0320-E/D  
(SHOWN WITH OPTIONAL CO AND H<sub>2</sub>S MONITORS)

- › **PRESSURE:**  
Up to 6000 PSIG (414 BAR)
- › **CHARGING RATE:**  
13 SCFM (368 L/MIN)
- › **POWER:**  
10 to 18 HP (7.5 to 13 kW)



### STANDARD SCOPE OF SUPPLY

- › BAUER breathing air purification system
- › TEFC motor
- › NEMA 4 rated electrical enclosure with **UL**® listed control panel
- › Compressor low oil pressure and high temperature safety shutdowns
- › Emergency stop push button
- › Automatic condensate drain system with non-corrosive condensate reservoir and integrated float switch and automatic “Full” indication and compressor shutdown
- › Gauge panel
- › Lifting eyes integral to unit frame
- › Inlet particulate filter and maintenance indicator
- › On/off switch and final air pressure switch
- › Powder coated aluminum frame and cabinet enclosure
- › 316 stainless steel tubing
- › Stainless steel fittings, fixtures and fastening devices
- › 3rd party certified for operations at 55°C

### DIESEL ENGINE DRIVEN MODELS

- › Name plated for operations at 55°C
- › Air-cooled diesel
- › Electric clutch and speed control solenoid
- › Spark arrestor muffler
- › Anti-vibration mounts for engine

### AVAILABLE ACCESSORIES (FACTORY INSTALLED)

- › CO monitoring system
- › SECURUS - Electronic moisture monitoring for the purification system
- › H<sub>2</sub>S monitoring system with audible alarm

### SYSTEM FOOTPRINT

- DIMENSIONS L X W X H inches (mm)**
- › 61” x 37” x 41” (1549.4mm x 940mm x 1041.4mm)
- WEIGHT pounds (kg)**
- › 650 - 750 lb (295 - 340 kg)

### TECHNICAL DATA

Model	Charging Rate <sup>1</sup>		Number of Stages	Motor		FAD <sup>2</sup>	RPM	Purification System
	SCFM	L/MIN		HP	kW			
<b>6000 PSIG (414 BAR)</b>								
0320-D	13	368	4	18	13	10.8	1420	P2
0320-E	13	368	4	10	7.5	10.8	1420	P2

1) Based on recharging an 80 cubic foot tank from 500 to 3000 psig.  
 2) Compressor capacity referenced to standard inlet conditions.  
 D=Diesel engine driven. E3=Three phase electric, 208/230/460 VAC/60 Hz. Other voltages available on request. Dimensions and weight are approximate and are subject to change.

FIRE

FIRE



# O26D-ESSM

## 4-STAGE HIGH PRESSURE BREATHING AIR COMPRESSORS

The O26D-ESSM air-cooled, oil-lubricated, four-stage, four-cylinder, single-acting, reciprocating compressor and purification system that supplies breathing air that meets or exceeds the requirements of CGA Pamphlet G-7, Compressed Air for Human Respiration, ANSI/CGA G-7.1, Commodity Specification for Air, Grade E, and all other recognized standards for respirable air. Built on a horizontal aluminum frame designed to be capable of continuous duty operation with temperatures between 40°F and 115°F. All instrument tubing comprises 316 stainless steel, fittings, and fastening devices. The O26D-ESSM has a 27 HP water-cooled diesel engine with an electric start, electrically actuated clutch, and speed control solenoid.

- › **PRESSURE:**  
Up to 6000 PSIG (414 BAR)
- › **CHARGING RATE:**  
26 SCFM (747.56 L/MIN)
- › **POWER:**  
27 HP (20 kW)



### STANDARD SCOPE OF SUPPLY

- › NEMA 4 enclosure
- › On / off selector switch
- › Emergency stop
- › Final air pressure shutdown
- › Warning and alarm indicator lights
  - All lamps are a minimum 22 mm diameter
  - Lamp test function built in
  - Lamps flash code representing fault
- › Nonresettable hourmeter
- › Oil pressure switch and pressure gauge
- › Temperature switch
- › Low oil pressure and high-pressure air shutdown switches equipped with DIN type connectors
- › Purification system quality that meets or exceeds the requirements of CGA Pamphlet G-7, Compressed Air for Human Respiration, ANSI/CGA G-7.1, Commodity Specification for Air, Grade E, and all other recognized standards for breathing air
- › Built in overtime timer set at 5 hours (optional times available)
- › Final separator counter warning and alarm functions
- › UL listed panel
- › Single pressure switch & air outlet set for 5000 PSI
- › Highstar model 82647 air discharge kit
- › CO monitoring system
- › SECURUS - Electronic moisture monitoring for the purification system
- › Name plated for operations at 40°F-115°F
- › Water-cooled diesel
- › Electric clutch and speed control solenoid
- › Spark arrestor muffler
- › Anti-vibration mounts for engine

### SYSTEM FOOTPRINT

- DIMENSIONS L X W X H inches (mm)**
- › 69.875" x 57.5" x 54.25" (1774.75mm x 1460.5mm x 1377.95mm)
- WEIGHT pounds (kg)**
- › 1300 lb (589.67 kg)

### TECHNICAL DATA

Model	Charging Rate <sup>1</sup>	Number of Stages	Motor	FAD <sup>2</sup>	RPM	Purification System	Air Processing Capability <sup>3</sup>
	SCFM		HP	SCFM			cu ft
<b>UP TO 6000 PSIG (414 BAR)</b>							
O26-D	26.4	4	27	22.0	1350	P10S	230,000

<sup>1</sup> Based on standard inlet conditions.  
<sup>2</sup> Based on recharging an 80 cu ft cylinder from 500 to 3000 PSIG.  
<sup>3</sup> Based on an inlet temperature of 70°F.

FIRE

FIRE

# O26-E3/ESSM

## 4-STAGE HIGH PRESSURE BREATHING AIR COMPRESSORS

The O26-E3-ESSM air-cooled, oil-lubricated, four-stage, four-cylinder, single-acting, reciprocating compressor and purification system that supplies breathing air that meets or exceeds the requirements of CGA Pamphlet G-7, Compressed Air for Human Respiration, ANSI/CGA G-7.1, Commodity Specification for Air, Grade E, and all other recognized standards for respirable air. Built on a horizontal aluminum frame designed to be capable of continuous duty operation with temperatures between 40°F and 115°F. All instrument tubing comprises 316 stainless steel, fittings, and fastening devices. The O26E3-ESSM has a 20 HP T.E.F.C. electric motor with a v-belt drive powering the compressor.

- › **PRESSURE:**  
Up to 6000 PSIG (414 BAR)
- › **CHARGING RATE:**  
26.4 SCFM (747.56 L/MIN)
- › **POWER:**  
20 HP (14.9 kW)



### STANDARD SCOPE OF SUPPLY

- › NEMA 4 enclosure
- › On / off selector switch
- › Emergency stop
- › Final air pressure shutdown
- › Warning and alarm indicator lights
  - All lamps are a minimum 22 mm diameter
  - Lamp test function built in
  - Lamps flash code representing fault
- › Nonresettable hourmeter
- › Built in overtime timer set at 5 hours - optional times available
- › Final separator counter warning and alarm functions
- › Full support of SECURUS warning and alarm functions
- › Motor overload alarm
- › UL listed panel
- › Dual pressure switch w/separate outlet ports (3000 PSI/5000 PSI)
- › Highstar model 82647 & 82647A air discharge kits for low & high outlet ports
- › Securus electronic purification system moisture monitor

### AVAILABLE ACCESSORIES (FACTORY INSTALLED)

- › Purification System upgrades
- › Carbon monoxide monitor with calibration kit
- › Audible alarm for all safety shutdowns
- › Storage systems
- › Fill station

### SYSTEM FOOTPRINT

- DIMENSIONS L X W X H inches (mm)**
- › 69.875" x 57.5" x 54.25" (1774.75mm x 1460.5mm x 1377.95mm)
- WEIGHT pounds (kg)**
- › 1300 lb (589.67 kg)

### TECHNICAL DATA

Model	Charging Rate <sup>1</sup>	Number of Stages	Motor	FAD <sup>2</sup>	RPM	Purification System	Air Processing Capability <sup>3</sup>
	SCFM		HP	SCFM			cu ft
<b>UP TO 6000 PSIG (414 BAR)</b>							
O26-E3	26.4	4	20	22.0	1350	P10S	230,000

<sup>1</sup> Based on standard inlet conditions.  
<sup>2</sup> Based on recharging an 80 cu ft cylinder from 500 to 3000 PSIG.  
<sup>3</sup> Based on an inlet temperature of 70°F.

FIRE

FIRE



# ENGINE DRIVEN

## 4- AND 5-STAGE HIGH-PRESSURE BREATHING AIR COMPRESSORS

The ENGINE DRIVEN compressor for recharging SCBA or SCUBA cylinders combines compressor, purification system, and engine drive. The frame's rugged design is specific to the requirements of the engine drive/compressor block assembly.

- › **PRESSURE:**  
Up to 6000 PSIG (414 BAR)
- › **CHARGING RATE:**  
13 to 60 SCFM  
(368 to 1700 L/MIN)
- › **POWER:**  
18 to 60 HP (13 to 45 kW)



› H25-D

### STANDARD SCOPE OF SUPPLY

- › BAUER breathing air purification system with B-SECURUS
- › BAUER PLC base controller with four line text display
- › NEMA 4 rated electrical enclosure with hourmeter
- › Compressor low oil pressure and high temperature safety shutdowns
- › Emergency stop push button
- › Automatic condensate drain system with non-corrosive condensate reservoir and integrated float sensor and automatic "Full" indication and compressor shutdown
- › Interstage pressure gauges
- › Electric start package including electric clutch and speed control solenoid
- › Closed loop water-cooled diesel

### AVAILABLE ACCESSORIES (FACTORY INSTALLED)

- › BAUER Gas-Tek™ CO monitoring system
- › H<sub>2</sub>S monitoring system

### TECHNICAL DATA

Model	Charging Rate <sup>1</sup>		Number of Stages	Motor		FAD <sup>2</sup>	RPM	Purification System
	SCFM	L/MIN		HP	kW			
<b>5000 PSIG (345 BAR)</b>								
K20-D	21	595	4	27	20	17.5	1300	P5 B-SECURUS
K26-D	26.4	748	4	27	20	22	1350	P5 B-SECURUS
K42-D	42	1190	4	44	33	35	1300	P10 B-SECURUS
K60-D	60	1700	4	60	45	50	1350	P12 B-SECURUS
<b>6000 PSIG (414 BAR)</b>								
H13-D	13	368	4	18	13	10.8	1420	P2 B-SECURUS
H18-D	18	510	4	27	20	15	1325	P5 B-SECURUS
H25-D	25.2	714	5	27	20	21	1300	P5 B-SECURUS
H35-D	35.9	1017	4	44	33	29.8	1200	P10 B-SECURUS

<sup>1</sup>) Based on recharging an 80 cubic foot tank from 500 to 3000 psig.  
<sup>2</sup>) Compressor capacity referenced to standard inlet conditions.

### SYSTEM FOOTPRINT

- H13-K26:**  
**DIMENSIONS L X W X H inches (mm)**  
 › 63" x 49" x 46" (1600mm x 1245mm x 1168mm)  
**WEIGHT pounds (kg)**  
 › 1300 - 3750 lb (590 - 1700 kg)
- H35-K42:**  
**DIMENSIONS L X W X H inches (mm)**  
 › 95" x 52" x 49" (2413mm x 1320mm x 1245mm)  
**WEIGHT pounds (kg)**  
 › 1300 - 3750 lb (590 - 1700 kg)
- K60:**  
**DIMENSIONS L X W X H inches (mm)**  
 › 112" x 52" x 53" (2845mm x 1346mm x 1320mm)  
**WEIGHT pounds (kg)**  
 › 1300 - 3750 lb (590 - 1700 kg)

FIRE

# DDTR26-WRAF

## SCHEDULE MAS:

Total solutions for law enforcement, security, facilities management, fire, rescue, clothing, marine craft and emergency/disaster response.

**NAICS CODE #333912 | NSN 4310-01-515-9940**

Our aesthetically pleasing enclosure encompasses the compressor system from inclement weather and road debris and the heavy-duty frame provides a firm foundation for up to four air storage cylinders. The single axle design enhances mobility with most

smaller vehicles.

- › **PRESSURE:**  
5000 PSIG (345 BAR)
- › **CHARGING RATE:**  
26.4 SCFM (748 L/MIN)
- › **POWER:**  
27 HP (20 kW)
- › **CONTRACT PERIOD:**  
09/21/17 - 09/20/22



› DDTR26-WRAF

## STANDARD SCOPE OF SUPPLY

- › Manufactured in compliance with the National Trailer Manufacturers Association (NATM) guidelines
- › NFPA 1901 2016 edition compliant 2 position containment fill station accommodates SCBA or SCUBA cylinders up to 31" overall length
- › Unique diesel/electric dual drive system incorporating our exclusive automatic belt tensioning system
- › High gloss powder coat paint for a hard durable finish
- › Hydraulic surge brakes with breakaway actuator
- › Bulk fill pneumatic logic
- › Four (4) DOT/UN air storage cylinders with bulk fill pneumatic logic
- › Formed structural steel frame designed and built by BAUER
- › Hypalon® type cover protection for the operations panel and fill station
- › Telescoping light mast with four 500 watt fixtures, snorkel tube for compressor air inlet integrated with light mast and 7500 watt auxillary generator
- › 7.5 kW belt driven generator

## SYSTEM FOOTPRINT

- DIMENSIONS L x W x H inches (mm)**
- › 182" x 94.25" x 103" (4470mm x 2394mm x 2063.75mm)
- WEIGHT pounds (kg)**
- › 5500 lb (2495 kg)

## AVAILABLE ACCESSORIES

- › Spare tire and wheel chocks with fender well storage
- › 100 ft. hose reel and interior lights
- › 2 5/6" ball hitch

## TECHNICAL DATA

Model	Charging Rate <sup>1</sup>		Number of Stages	Motor		FAD <sup>2</sup>	RPM	Purification System
	SCFM	L/MIN		HP	kW			
<b>5000 PSIG (4 14 BAR)</b>								
DDTR26-WRAF/GSA	26.4	748	4	27	20	22	1300	P5 SECURUS

1) Based on recharging an 80 cubic foot tank from 500 to 3000 psig.  
 2) Compressor capacity referenced to standard inlet conditions. Dimensions and weight are approximate and are subject to change.  
 A. BAUER COMPRESSOR warranty includes parts and labor 12 Months from the date of compressor start-up or 18 Months from the date of shipment.  
 B. Spare parts consisting of normal wear and tear items, e.g., replacement cartridges, valve overhaul kits, gasket kits, belts, oil, and inlet filter element, etc., are standard stock items at BAUER NORFOLK, BAUER SAN FRANCISCO, and BAUER NORTHEAST.

FIRE

FIRE



# TCOM LITE®

## 4- AND 5-STAGE HIGH-PRESSURE MOBILE BREATHING AIR RECHARGING SYSTEMS

If your needs do not require the amenities of the full-sized TCOM®, look to the T-COM LITE®. Designed and manufactured by BAUER for the budget-minded customer, the T-COM LITE® utilizes a multi-stage air-cooled compressor coupled to a water-cooled diesel engine. Our aesthetically pleasing enclosure encompasses the compressor system from inclement weather and road debris, and the heavy-duty frame provides a firm foundation for up to four (4) air storage cylinders. The single axle design enhances mobility with most smaller vehicles.

- › **PRESSURE:**  
6000 PSIG (414 BAR)
- › **CHARGING RATE:**  
13 to 25.2 SCFM (368 to 714 L/MIN)
- › **POWER:**  
18 to 27 HP (13.4 to 20 kW)



› TCOM LITE

### STANDARD SCOPE OF SUPPLY

- › BAUER breathing air purification system with B-SECURUS
- › BAUER PLC based controller with four line text display
- › NEMA 4 rated electrical enclosure
- › Automatic condensate drain system with non-corrosive condensate reservoir and integrated float sensor and automatic “Full” indication and compressor shutdown
- › Two (2) 6000 PSIG UN code stamped air cylinders
- › NFPA 1901 2016 edition compliant 2 position containment fill station accommodates SCBA or SCUBA cylinders up to 31” overall length
- › Unique diesel drive system incorporating our exclusive automatic belt tensioning system
- › High gloss powder coat paint for a hard durable finish
- › Hydraulic surge brakes with breakaway actuator
- › Four (4) bank dual function cascade controls with air direction valve
- › Formed structural steel frame designed and built by BAUER
- › Hypalon® type cover protection for the operations panel and fill station
- › Refill port
- › BAUER Gas-Tek™ CO monitoring system with calibration kit
- › 2” ball hitch

### SYSTEM FOOTPRINT

- DIMENSIONS L x W x H inches (mm)**
- › 144” x 77” x 72” (3658mm x 1956mm x 1830mm)
- WEIGHT pounds (kg)**
- › 5400 lb (2450 kg)

### AVAILABLE ACCESSORIES (FACTORY INSTALLED)

- › **Option Package A** - Spare tire with cover
- › **Option Package B** - 100 ft hose reel and interior lights
- › **Option Package C** - Lunette eye hitch
- › **Option Package D** - Two (2) additional 6000 PSIG UN code stamped air cylinders
- › **Option Package E** - Two (2) ASME cylinders in lieu of standard Two (2) UN cylinders

### TECHNICAL DATA

Model	Charging Rate <sup>1</sup>		Number of Stages	Motor		FAD <sup>2</sup>	RPM	Purification System
	SCFM	L/MIN		HP	kW			
<b>6000 PSIG (414 BAR)</b>								
TCL-13H	13	368	4	18	13.4	10.8	1420	P5 B-SECURUS
TCL-25H	25.2	714	5	27	20	21	1300	P5 B-SECURUS

1) Based on recharging an 80 cubic foot tank from 500 to 3000 psig.  
 2) Compressor capacity referenced to standard inlet conditions.  
 Image shown with additional accessories. Dimensions and weight are approximate and are subject to change.

FIRE

FIRE

# TCOM® TRAILER

## 4- AND 5-STAGE HIGH-PRESSURE MOBILE BREATHING AIR RECHARGING SYSTEMS

When your needs require a rugged trailer built for the fire service, rather than a cheap lightweight imitation, look to BAUER. Our TCOM® TRAILER designs are powered by a unique diesel/electric dual drive system. Each system is equipped with a 2 position containment fill station, an enclosed fill control panel, four ASME storage cylinders and integral SCBA storage for up to twelve SCBA cylinders all incorporated onto a heavy duty frame built by BAUER.

- › **PRESSURE:**  
6000 PSIG (414 BAR)
- › **CHARGING RATE:**  
13 to 25.2 SCFM (368 to 714 L/MIN)
- › **ELECTRIC MOTOR:**  
10 to 20 HP (7.5 to 15 kW)
- › **DIESEL ENGINE (EPA Tier 4 Compliant):**  
27 to 37 HP (20 to 27 kW)



› TCOM TRAILER

### STANDARD SCOPE OF SUPPLY

- › BAUER breathing air purification system with B-SECURUS
- › BAUER PLC based controller with four line text display
- › NEMA 4 rated electrical enclosure with UL® listed control panel
- › Automatic condensate drain system with non-corrosive condensate reservoir and integrated float sensor and automatic “Full” indication and compressor shutdown
- › Four (4) 6000 PSIG ASME code stamped air cylinders
- › Integral SCBA storage for up to twelve (12) SCBA cylinders
- › NFPA 1901 2016 edition compliant 2 position containment fill station accommodates SCBA or SCUBA cylinders up to 31” overall length
- › Unique diesel/electrical dual drive system incorporating our exclusive automatic belt tensioning system
- › High gloss powder coat paint for a hard durable finish
- › Hydraulic surge brakes with breakaway actuator
- › Four (4) bank dual function cascade controls with air direction valve
- › Formed structural steel frame designed and built by BAUER
- › Rolled shutter door protection for the operations panel and fill station
- › Refill port
- › BAUER Gas-Tek™ CO monitoring system with calibration kit
- › Lunette eye hitch

### AVAILABLE ACCESSORIES (FACTORY INSTALLED)

- › **Option Package A** - Telescoping light mast with four (4) 500 watt fixtures, snorkel tube for compressor air inlet integrated with light mast and 7500 watt auxiliary generator
- › **Option Package B** - Spare tire and wheel chocks with fender well storage
- › **Option Package C** - 100 ft hose reel and interior lights
- › **Option Package D** - 2 5/16” ball hitch
- › **Option Package E** - 100 1/2” L x 5 1/2” H sign boards

### TECHNICAL DATA

Model	Charging Rate <sup>1</sup>		Number of Stages	Motor/Engine		FAD <sup>2</sup>	RPM	Purification System
	SCFM	L/MIN		HP	kW			
<b>6000 PSIG (414 BAR)</b>								
TCOM-13H	13	368	4	10 - 27	7.5 - 20	10.8	1420	P5 B-SECURUS
TCOM-25H	25.2	714	5	20 - 37	15 - 27	21	1300	P5 B-SECURUS

<sup>1</sup> Based on recharging an 80 cubic foot tank from 500 to 3000 psig.  
<sup>2</sup> Compressor capacity referenced to standard inlet conditions.  
 Image shown with additional accessories. Dimensions and weight are approximate and are subject to change.

### SYSTEM FOOTPRINT

- DIMENSIONS L x W x H\* inches (mm)**
- › 200” x 90” x 105”\* (5080mm x 2286mm x 2267mm)
- WEIGHT pounds (kg)**
- › 8400 lb (3810 kg)
- \* with optional light mast

FIRE

FIRE



# MOBILE PACKAGE

When your department requires the need for a mobile breathing air truck, look no further than BAUER. For 75 years, BAUER has been the industry leader in high pressure breathing air compressor systems. We start with critical components designed, engineered, and manufactured in our factories. Our sales & engineering staff work closely with your truck manufacturer of choice to ensure the entire system meets your department's critical needs. Your closest factory authorized BAUER Partner is brought into the equation to maximize customer satisfaction and support with the product after the truck has been delivered to you.

## STANDARD SCOPE OF SUPPLY

- › Skid mounted BAUER multi-stage air-cooled compressor.
- › BAUER breathing air purification system with B-SECURUS electronic moisture monitoring system.
- › BAUER B-drain automatic condensate drain system with integral skid mounted collection reservoir
- › BAUER Gas-Tek™ CO monitoring system with calibration kit
- › BAUER PLC based controller with 7" color HMI touchscreen display
- › NEMA 4 rated electrical enclosure with UL® listed control panel
- › Single Phase & Three Phase Electrical Motor Voltage options
- › Soft start electronics to reduce initial start-up load on the truck mounted generator system
- › Compressor low oil pressure and high temperature safety shutdowns
- › Emergency stop push button
- › Stainless steel interconnecting piping
- › Air Storage Refill Port

## BAUER CFS5.5® FILL STATIONS:

- › Designed & Tested to meet NFPA 1901 2016 Edition Standards
- › BAUER CFS5.5® fill stations were tested & passed a 5500 PSIG SCBA rupture with 110 cu ft cylinder
- › Our standard fill stations can be supplied in a single, two, or three position configurations
- › Dual two & three position fill stations are popular with larger fire departments
- › Can accommodate many sized steel & Aluminum Dive Tanks
- › Remote Mounted HMI Compressor Controls are integrated into our fill station control panels
- › Top or Side Mounted DUAL Function Cascade Control Panels
- › Air selector valve to select filling "From Compressor / Fill From Storage"
- › ABS Risers located in each fill position to ensure proper height of SCBA cylinder within Fill Station
- › Custom Fill Control Panels to include High Pressure & Low-Pressure Hose Reel Controls

## AIR STORAGE OPTIONS:

- › UN DOT cylinders are rate to 6000 PSIG working pressure
- › 10 Year retest requirement for UN/ISO Cylinders.
- › ASME coded cylinders rated to 7000 PSIG working pressure (3:1 structural safety factor)
- › Safety Relief Valve installed on each ASME Cylinder along with moisture drain valve
- › All Cylinders are pre-piped with stainless steel tubing within compressor skid package
- › Cylinders can be shipped loose for custom installation within truck body

## CUSTOM DESIGNED SYSTEM:

- › Up to 7,000 PSIG
- › 13 to 35 SCFM (368 to 1017 l/min) Charging Rate
- › 10 to 30HP (7.5 to 22kw)
- › Electric and diesel driven
- › UN and ASME air storage cylinders
- › Custom air flow control panels
- › NFPA 1901 Approved, 3rd Party Tested Containment Fill Stations
- › Proven performance with over 35 years of experience

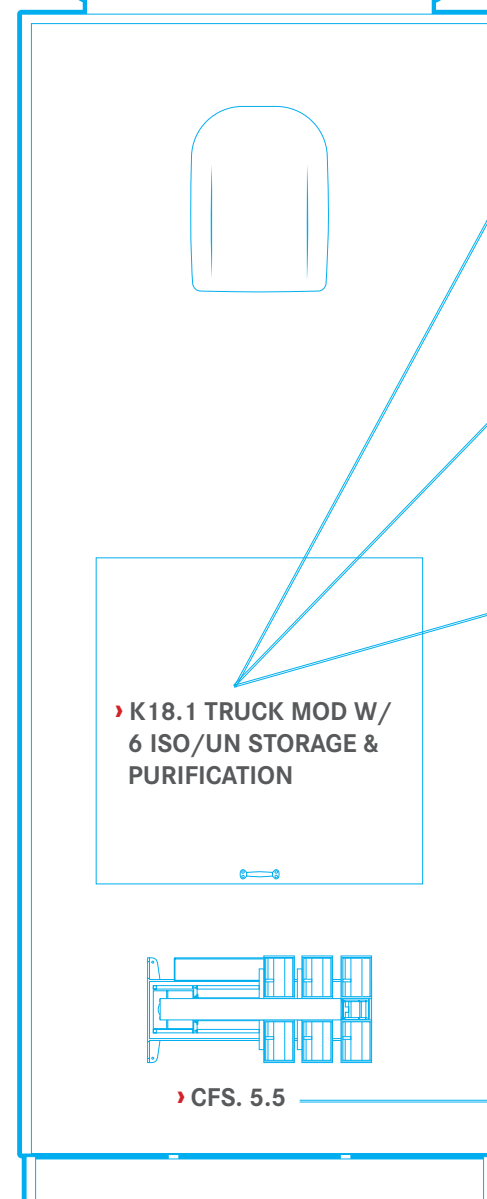
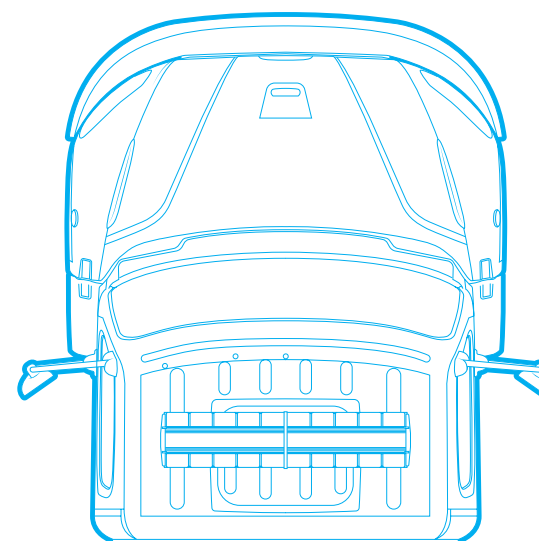

› FRONT VIEW

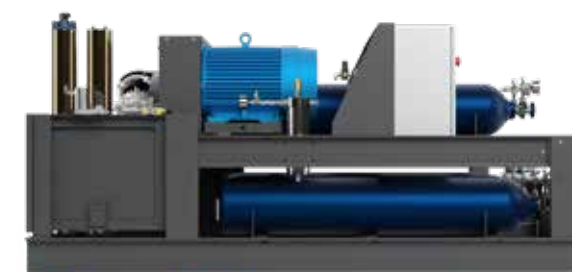

› SIDE VIEW



› AERIAL VIEW

› K18.1 TRUCK MOD W/  
6 ISO/UN STORAGE &  
PURIFICATION

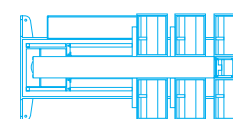

› CFS. 5.5



› CFS. 5.5

FIRE

FIRE

# OPEN DESIGNS

## 4- AND 5-STAGE HIGH-PRESSURE BREATHING AIR COMPRESSORS

Open packages in horizontal or vertical configurations combine compressor and air purification system in a space saving design. These compressors set the standard for larger capacity requirements.

- › **PRESSURE:**  
Up to 6000 PSIG (414 BAR)
- › **CHARGING RATE:**  
35.9 to 145 SCFM  
(1017 to 4106 L/MIN)
- › **POWER:**  
30 to 100 HP (22 to 75 kW)



› K60

### STANDARD SCOPE OF SUPPLY

- › BAUER breathing air purification system
- › BAUER PLC based controller with 7" color HMI touchscreen display
- › NEMA 4 rated electrical enclosure with UL® listed control panel
- › Compressor low oil pressure and high temperature safety shutdowns
- › Emergency stop push button
- › Automatic condensate drain system with non-corrosive condensate reservoir and integrated float sensor and automatic "Full" indication and compressor shutdown
- › Beltguard designed to meet OSHA guidelines
- › Soft start and fuse disconnect
- › Interstage pressure gauges (locally mounted)

### AVAILABLE ACCESSORIES (FACTORY INSTALLED)

- › BAUER Gas-Tek™ CO monitoring system
- › B-SECURUS - Electronic moisture monitoring for the purification system (K42V-E3 and K42-E3 only)
- › H<sub>2</sub>S monitoring system with audible alarm

### TECHNICAL DATA

Model	Charging Rate <sup>1</sup>		Number of Stages	Motor		FAD <sup>2</sup>	RPM	Purification System
	SCFM	L/MIN		HP	kW			
<b>5000 PSIG (345 BAR)</b>								
K42V-E3 <sup>3</sup>	42	1190	4	30	22	35	1300	P10
K42-E3 <sup>3</sup>	42	1190	4	30	22	35	1300	P10
K60-E3	60	1700	4	40	30	50	1350	P12 B-SECURUS
K80-E3	80.4	2277	4	60	45	67	1225	P14 B-SECURUS
K145-E3	145	4106	4	100	75	121	1125	P14 B-SECURUS
<b>6000 PSIG (414 BAR)</b>								
H35V-E3	35.9	1017	4	30	22	29.8	1200	P10 B-SECURUS
H35-E3	35.9	1017	4	30	22	29.8	1200	P10 B-SECURUS
H80-E3	80.4	2277	5	60	45	67	1180	2x P10 B-SECURUS
H96-E3	96	2718	5	75	56	80	1100	2x P10 B-SECURUS

<sup>1</sup> Based on recharging an 80 cubic foot tank from 500 to 3000 psig.  
<sup>2</sup> Compressor capacity referenced to standard inlet conditions.  
<sup>3</sup> SECURUS electronic moisture monitoring is not standard.  
 E3=Three phase electric, 208/230/460 VAC/60 Hz. Other voltages available on request. KV/HV= VERTICAL. K/H= HORIZONTAL. Dimensions and weight are approximate and are subject to change.

### SYSTEM FOOTPRINT

- VERTICAL:**  
**DIMENSIONS L X W X H inches (mm)**  
 › **K42V/H35V:** 65" x 42" x 75" (1667mm x 1051mm x 1905mm)  
**WEIGHT pounds (kg)**  
 › 1200 - 2800 lb (544 - 1270 kg)
- HORIZONTAL:**  
**DIMENSIONS L X W X H inches (mm)**  
 › **K42/H35:** 95" x 44" x 61" (2413mm x 1117mm x 1549.4mm)  
 › **K60:** 92" x 44" x 61" (2337mm x 1117mm x 1549.4mm)  
 › **K80/K145:** 116" x 84" x 67" (2946.4mm x 2134mm x 1702mm)  
**WEIGHT pounds (kg)**  
 › 1200 - 5000 lb (544 - 2268 kg)

FIRE

FIRE



# CFS5.5®

## CONTAINMENT FILL STATIONS FOR AIR AND OXYGEN

Choose from a complete line of containment fill stations suitable for SCBA or SCUBA cylinders. Whether you need a 3, 2 or single-position fill station, be assured each model was proof tested by an independent lab to safely contain fragments of a ruptured 5500 PSIG 110 cu. ft. SCBA cylinder at maximum operating pressure in accordance with the 2016 Edition of NFPA 1901 and or 1989. Ask about our custom options to tailor a model to your specific requirements.

› **FILL POSITIONS:**

- One, two, or three
- Mobile or Stationary

› **CUSTOM DESIGNED SYSTEM:**

- Dual function cascade controls (2 or 3 position)
- Remote fill outlets



› CFS5.5-3S



› **CFS5.5®-3S/Package A**  
Shown with Cascade controls and regulated remote fill

## STANDARD SCOPE OF SUPPLY

- › Complete with cylinder scuff guard, SCBA fill connection, fill hose and bleed valve
- › Fill control panel with adjustable regulator, relief valve, manual control valve and pressure gauge for each fill position ("S" version only)
- › CFS5.5® "M" versions designed for use with remote air distribution panel
- › Mounting base is standard on "S" version and optional on "M" version
- › Convenient door handle actuation
- › Bottom venting
- › Reduced footprint



› CFS5.5®-1S



› CFS5.5®-2S



› CFS5.5®-2S/ Package A



› OXY-2S\*

## SYSTEM FOOTPRINT

**CFS5.5®-1S & OXY-1S:**

**DIMENSIONS L X W X H inches (mm)**

- › 18" x 21" x 55" (457mm x 533mm x 1397mm)

**WEIGHT pounds (kg)**

- › 433 lb (196 kg)

**CFS5.5®-1M & OXY-1M:**

**DIMENSIONS L X W X H inches (mm)**

- › 18" x 21" x 39" (457mm x 533mm x 990mm)

**WEIGHT pounds (kg)**

- › 360 lb (163 kg)

**CFS5.5®-2S & OXY-2S:**

**DIMENSIONS L X W X H inches (mm)**

- › 30" x 21" x 57" (762mm x 533mm x 1448mm)

**WEIGHT pounds (kg)**

- › 670 lb (304 kg)

**CFS5.5®-2M & OXY-2M:**

**DIMENSIONS L X W X H inches (mm)**

- › 30" x 21" x 39" (762mm x 533mm x 990mm)

**WEIGHT pounds (kg)**

- › 550 lb (249 kg)

**CFS5.5®-3S:**

**DIMENSIONS L X W X H inches (mm)**

- › 41" x 21" x 57" (1041mm x 533mm x 1448mm)

**WEIGHT pounds (kg)**

- › 905 lb (411 kg)

**CFS5.5®-3M:**

**DIMENSIONS L X W X H inches (mm)**

- › 41" x 21" x 39" (1041mm x 533mm x 990mm)

**WEIGHT pounds (kg)**

- › 740 lb (336 kg)

\*All components in Oxygen stream are Oxygen cleaned in compliance with A.S.T.M. Standard G-93. Dimensions and weight are approximate and are subject to change. Images shown with additional accessories.

# AIR STORAGE

## UN AND ASME STORAGE SYSTEMS

BAUER high pressure air storage systems meet the code requirements of both the United Nations Model Regulations and the American Society of Mechanical Engineers. Storage cylinders and storage systems are offered for 5000, 6000 and 7000 PSIG applications. Optional mounting racks are available.

- › **PRESSURE:**  
5000 PSIG (345 BAR)  
6000 PSIG (414 BAR)  
7000 PSIG (476 BAR)
- › **CONFIGURATION:**  
Vertical  
Horizontal
- › **STORAGE:**  
Bulk  
Bank



› UN STORAGE



› ASME STORAGE

REFERENCE ASY-0759 FOR VERTICAL CONFIGURATIONS  
AND ASY-0758 FOR HORIZONTAL CONFIGURATIONS

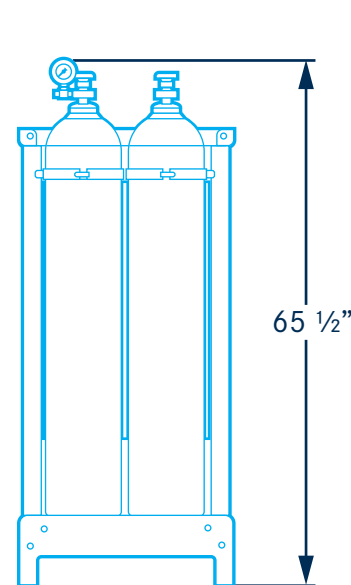

› UN STORAGE

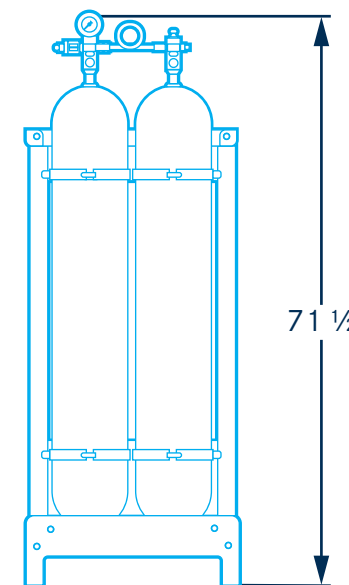

› ASME STORAGE

Model	Weight 2-Cylinder Rack	
	lbs	kg
UN 5000	475	215
UN 6000	525	238
ASME	935	424

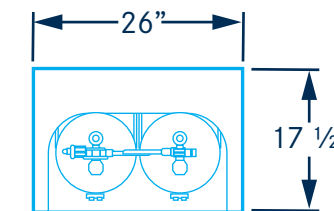

### TYPICAL SYSTEMS SHOWN BELOW

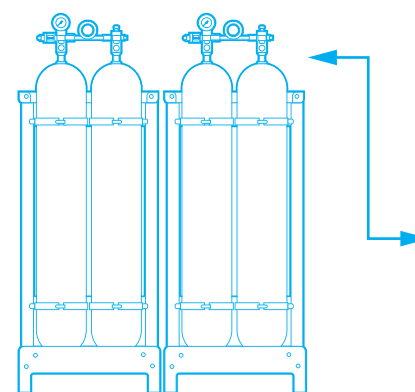

› BULK STORAGE SYSTEM  
ASME 4/BANK

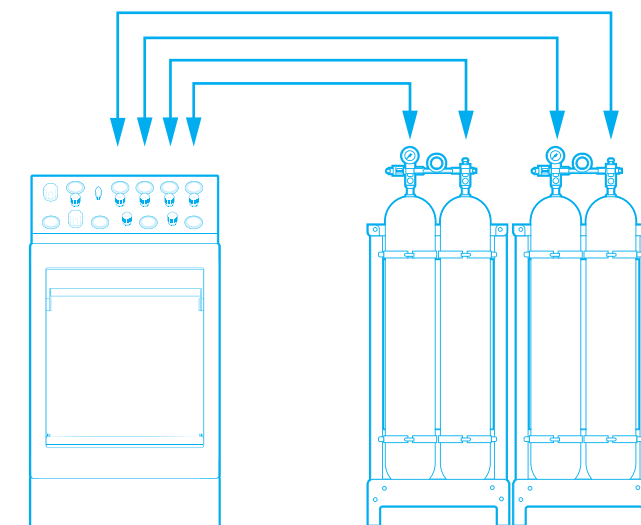

› FOUR BANK CASCADE STORAGE SYSTEM  
ASME 4/BANK/1-1-1-1



## BAUER CRC™ CHARGE RATE CONTROL

The BAUER Charge Rate Controller (CRC™) has been designed to automatically fill SCBA and SCUBA cylinders to their maximum allowable pressure as well as allow the operator performing the fill to control the charge rate avoiding hot fills and maximize stored air in the cylinders.



### BENEFITS:

- › Reduce complexity - No more fidgeting with dials; the BAUER CRC™ automatically charges SCBA and SCUBA cylinders to the right pressure with the push of a button.
- › Avoid “hot fills”, maximize stored air - Filling SCBA or SCUBA cylinders too fast will decrease the stored air in the cylinder when the cylinder cools down after charging. The BAUER CRC™ avoids this by controlling the rate of charge.
- › Allows for three different charge rate settings with the push of a button
- › Can be adapted to existing BAUER compressor systems

### OPERATION:

The BAUER CRC™ makes automatic filling of an SCBA or SCUBA cylinder easy with these three steps:

- › **Step 1:** From the main menu select the SCBA or SCUBA cylinder you wish to fill
- › **Step 2:** Select the desired charge rate from one of three options: Normal, Hot Fill or Custom
- › **Step 3:** Press “Start Fill”

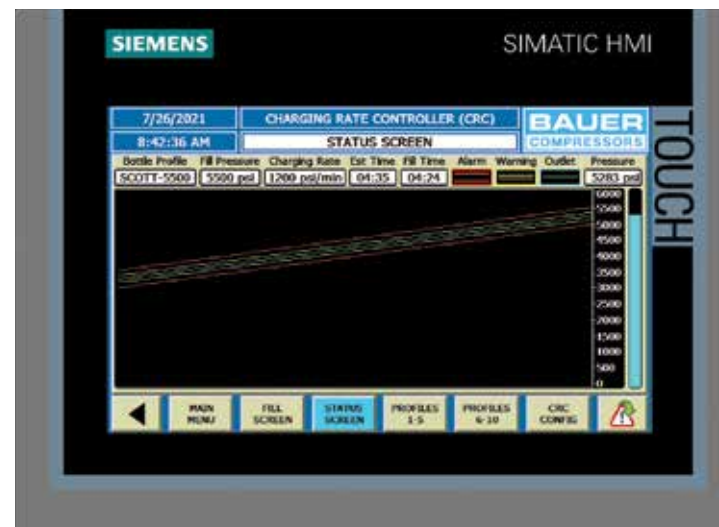
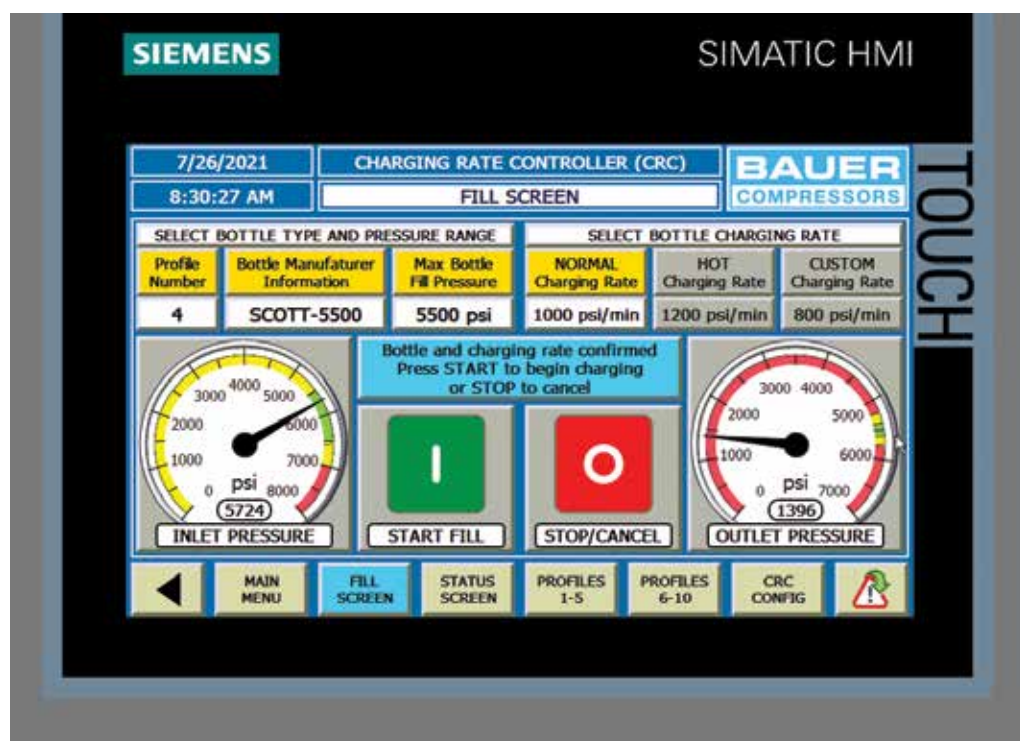

### STATUS SCREEN

Indicates Fill Rate & Cylinder Pressure

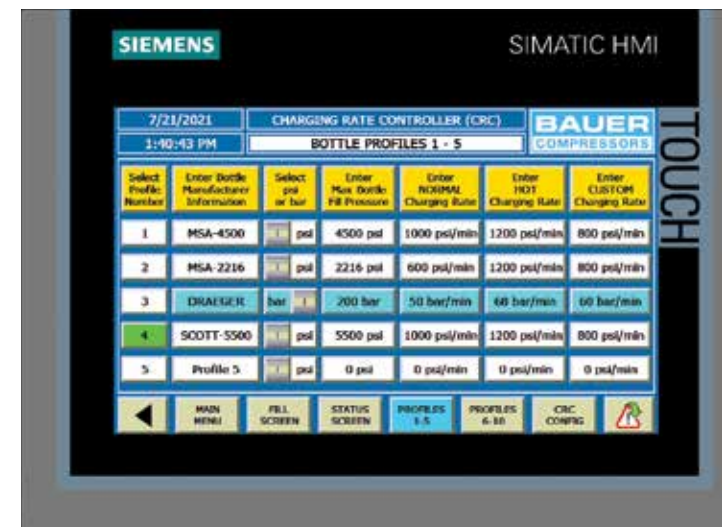

### CUSTOMIZABLE CYLINDER PROFILE SCREEN

### FEATURES

- › PLC controlled with color HMI touchscreen
- › Select from up to 10 customizable SCBA or SCUBA cylinder configurations, each with their own name designation and max fill pressure
- › Select from up to three customizable charge rates
- › Fill rate is accurately controlled with BAUER’s proprietary technology
- › Compatible with cascade storage and containment fill stations
- › Field retrofit to existing BAUER compressor systems
- › Easy installation: wall mountable; requires only two high pressure hose connections and plug-in 110V power

### SYSTEM SPECIFICATIONS

#### DIMENSIONS L x W x H

- › 7.5” x 21” x 26” (190.5mm x 533.4mm x 660.4mm)

#### WEIGHT

- › 40 lbs (18 kg)

#### MAXIMUM INLET PRESSURE

- › 6000 PSIG (414 BAR)

#### MAXIMUM FILL PRESSURE

- › 5500 PSIG (379 BAR)

#### HIGH-PRESSURE CONTROL PRESSURE PORT:

- › 1/4” NPT female

#### HIGH-PRESSURE FILLING INLET PORT:

- › 1/4” NPT female

#### HIGH-PRESSURE FILLING OUTLET PORT:

- › 1/4” NPT female

# PURIFICATION



## HIGH-PRESSURE BREATHING AIR PURIFICATION FOR BAUER SYSTEMS

BAUER Air Purification Systems purify high-pressure air to a quality that meets or exceeds the requirements of CGA Pamphlet G-7, Compressed Air for Human Respiration, ANSI/CGA G-7.1, Commodity Specification for Air, Grade E, and all other recognized standards for breathing air. Recognizing that filtration systems are unfortunately one of the most often overlooked systems, BAUER always utilizes the highest quality components to protect the system operator. Every BAUER high-pressure breathing air purification system final separator, from the P41 to the P10, is manufactured from high-strength chromium steel alloy, which never requires hydrotesting! All BAUER 6,000 PSI purification chambers are manufactured from a high-strength aluminum alloy that satisfies the 4:1 structural safety factor requirements specified within NFPA-1901 and NFPA-1989 codes. Our purification systems can also be retrofitted for integration into most brands of high-pressure breathing air compressor systems manufactured today!

› **WORLDWIDE LEADER:**

- Compressors
- Purification and filtration

› **ANODIZED ALUMINUM FILTER CARTRIDGE:**

- Filter cartridge end caps are machine crimped
- Eliminating glues/friction welding

› **ANODIZED ALUMINUM FILTER CHAMBERS:**

Each chamber and plug assembly are serialized to assure system traceability



› SECURUS

Images shown may have optional features.



› B-TIMER



› P0 TRIPLEX



› P31 SUPER TRIPLEX

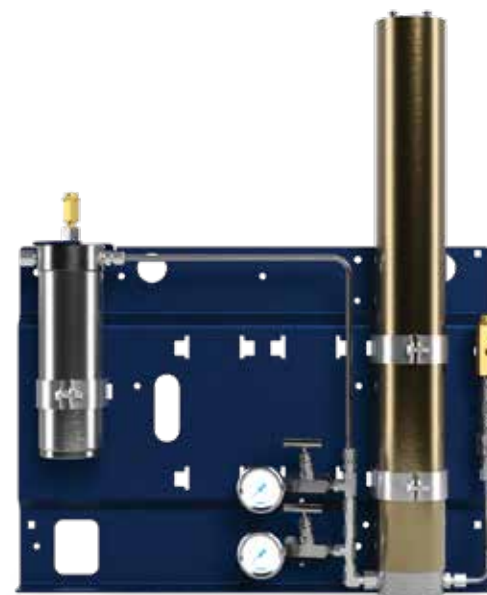

› P2

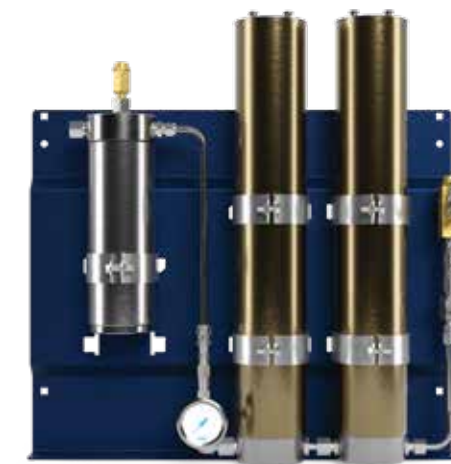

› P42

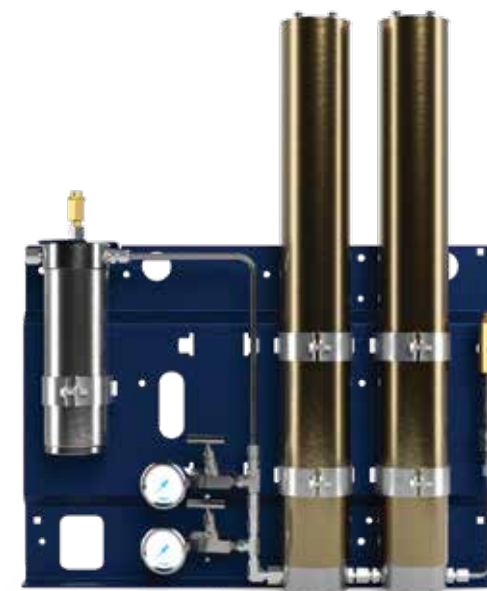

› P5

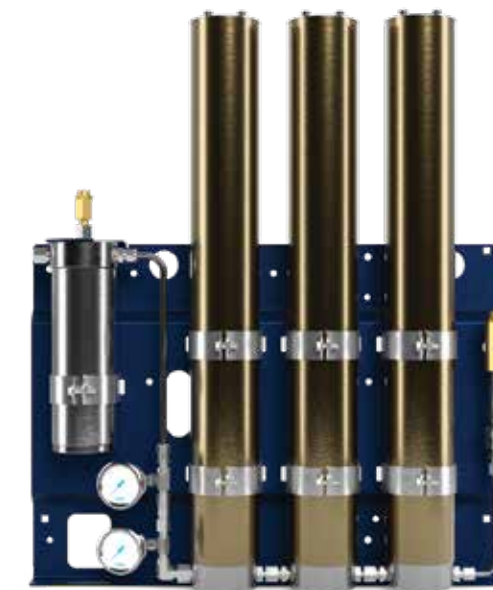

› P10



## BAUER \*B-VIRUS FREE®

\*THE B-VIRUS FREE™ FILTER ELIMINATES UP TO 99.9% OF CORONAVIRUSES, BACTERIA AND CERTAIN MOLDS FROM INTAKE AIR.

### COMPRESSOR INTAKE AIR FILTRATION SYSTEM FOR SAFETY WITHOUT COMPROMISE

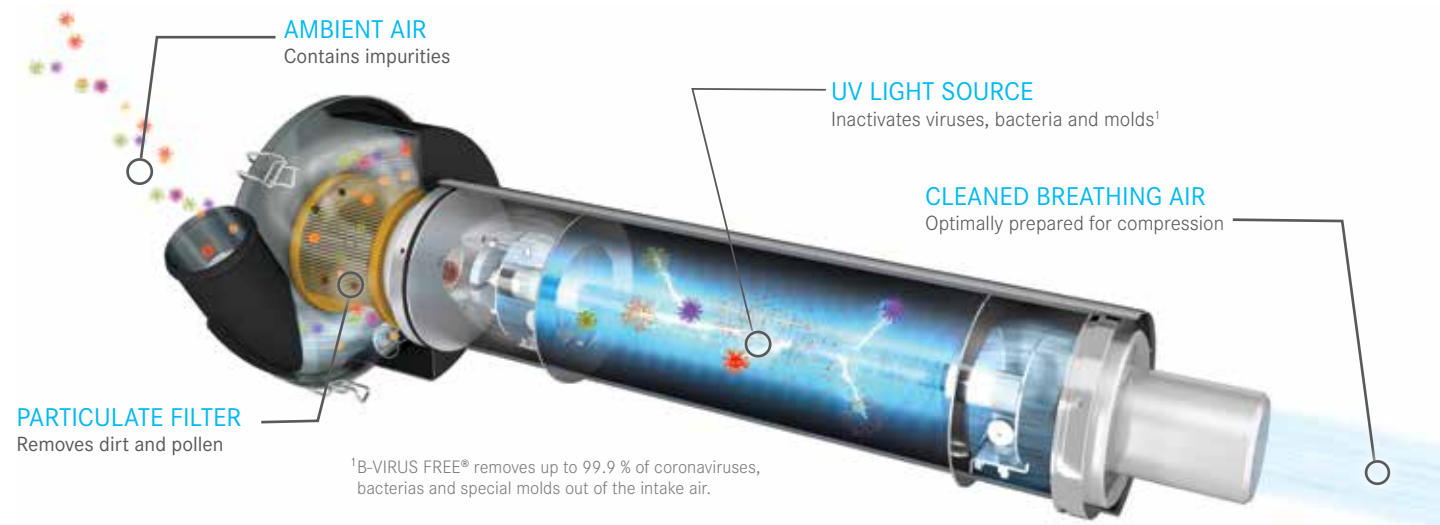

## PROTECTING YOUR HEALTH IS OUR NUMBER ONE PRIORITY

Science has shown that viruses and bacteria can spread rapidly over great distances through aerosol dispersion. Mixed in the ambient air, they can pass through any commercially available standard air purification system which is part of the typical breathing air compressor system. Even the high temperatures and pressures of a typical high-pressure breathing air compressor have little effect on viruses and bacteria because of their short-duration exposure to the process.

The new BAUER B-VIRUS FREE® breathing air filtration system (patent-pending) inactivates up to 99.9% of viruses including coronaviruses, bacteria, and molds at the air intake section of your BAUER breathing-air-compressor. The system is designed to protect firefighters, divers, hazardous-location-workers, military personnel, or anyone who breathes compressed breathing air through SCBA or SCUBA cylinders. EPA Est. No. 100175-VA-1



### INTAKE PARTICULATE FILTER

Underpressure in the compressor draws in air through the intake filter opening. Normal dust particles and even pollen are removed from the air by the intake filter.



### CONTROL AND DISPLAY

The control unit of the B-VIRUS FREE® protective filter system monitors functions and controls the UV light source. Operational status information is provided by visual (LED) and acoustic signals.



### CONNECTION TO COMPRESSOR

The B-VIRUS FREE® protective filter system is connected to a specially sealed intake hose, which eliminates any potential new contamination from leaks between the protective filter and the compressor block.



### UV PURIFICATION

The specially designed UV light source emits high-energy UVC radiation that destroys the molecular bonds in the DNA of bacteria and molds and in the RNA of viruses. This prevents the pathogens from reproducing.



### OZONE FREE

The B-VIRUS FREE® filter system produces no harmful ozone.

## EFFECTIVE INACTIVATION OF CORONA VIRUSES, BACTERIA AND MOLDS

Free of chemicals and ozone, the B-VIRUS FREE® system uses a specially designed UVC light source to destroy the pathogens before the intake air section of the compressor. The highly effective wavelength in the B-VIRUS FREE® system is absorbed by the pathogens' DNA, where the photons destroy the bonds between the DNA strands of the viruses, bacteria, and mold spores and effectively prevent them from reproducing.

## LOW MAINTENANCE, LOW OPERATING COSTS

The B-VIRUS FREE® compressor intake air filter system has long maintenance intervals to keep operating costs down. The filter does not require replaceable filter cartridges. The UVC light source has an extremely long service life of approx. 2,000 hours and is simple to replace.

## EASY INTEGRATION INTO YOUR BAUER COMPRESSOR SYSTEM

The B-VIRUS FREE® compressor air intake filter system can be ordered for any new model BAUER VERTECON®, VERTICUS®, BAUER LEGACY®, and UNICUS® 4S & 4i breathing air compressor systems. B-VIRUS FREE® will also be available as a retrofit kit for older BAUER breathing air compressor systems.



**VERTECON®**  
The B-VIRUS FREE® system shown integrated into the BAUER VERTECON® Breathing Air Compressor System

## TECHNICAL DATA

B-VIRUS FREE®	
	Values
<b>APPLICATION</b>	
Pressure Range	Atmospheric Intake Air
Compressor Charge Rate Range	3.5-30 scfm (100 - 850 l/min)
<b>FUNCTIONS</b>	
Required Warm-Up Time	60 secs
Visual Indicators	Warm-up/Normal/Fault
Audible Signal	in case of fault
<b>TECHNICAL DATA</b>	
Permissible operating temperature range	+41°F(+5°C) to +105°F (+40°C)
Operating voltage	110/220 volts, ac, single phase (60/50Hz)
UV lamp service life	2,000 hrs or every 2 years
Weight filter unit	approx. 17.5 lbs (7kg)
Weight control box	approx. 12.5 lbs (5kg)
Dimensions W x D x H	36x10x18 in (905x250x450 mm)

The B-VIRUS FREE® filter eliminates up to 99.9% of coronaviruses, bacteria and certain molds from intake air.



## BAUER CONNECT® REMOTE TELEMETRY AND CONTROL VIA MOBILE APP

For over 75 years, BAUER has been the leader in breathing air products for firefighters. So we understand that every wasted minute leads to injury, smoke exposure, or worse. That's why we developed BAUER CONNECT® IoT Solutions for Firefighting – our all-in-one, mobile telemetry solution for optimal ease-of-use and efficiency. Now you can view your SCBA fill data logs, get notifications about your compressor, and remotely control and monitor your BAUER compressor. The best part is that BAUER CONNECT® can be tailored to fit your station's needs.

BAUER CONNECT® – Connection that matters.

### Security Features:

- › Multiple logical & physical security layers
- › Privilege and separation rights
- › AI/ML threat assessment & analysis
- › Transport layer encryption and encryption at rest
- › Extensive logging and monitoring of network, system and application events

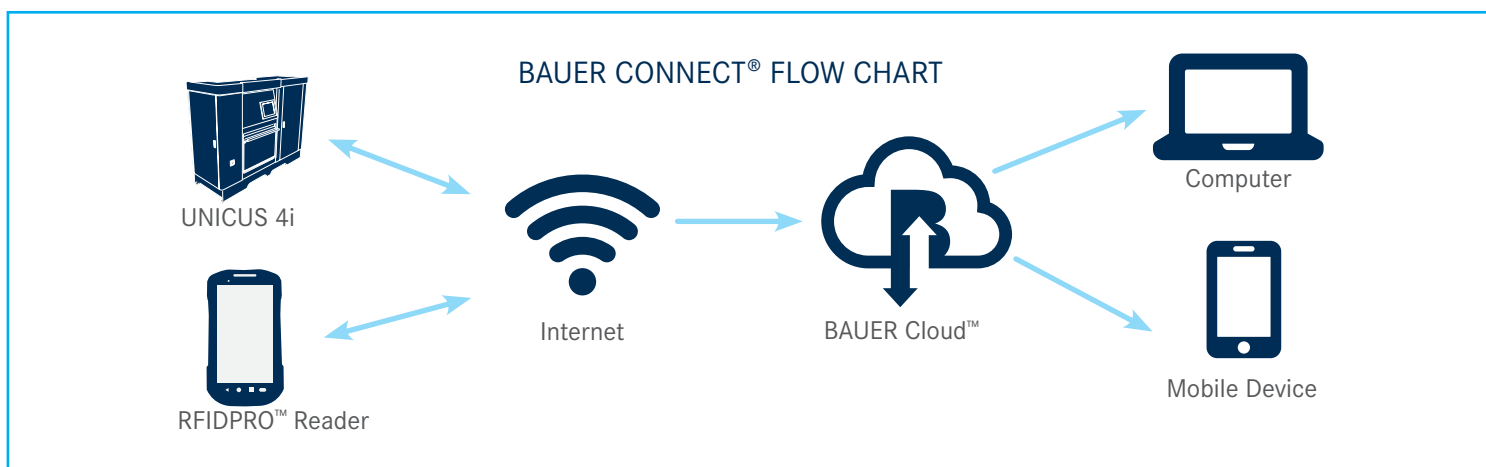

Available on



To sign up and register go to Signup: Bauer-Connect.com

## BAUER CONNECT® FUNCTIONS OVERVIEW



### BAUER REPORTS

BAUER Reports is a function that generates custom reports tailored to the specific needs of the customer.

#### SCBA Management Report

- › Generate a report per NFPA 1989 data logging requirements
- › Show when your cylinders were last filled and by who etc.
- › Fill Status Warning: Lists the SCBA the cylinder in inventory that have not been filled within the year
- › Fill activity: Lists the SCBA cylinders serial number, Person filling, RFID serial, cylinder pressure and dates of fill
- › Personnel: List or edit admin, users with privilege to log in to BAUER CONNECT®



#### Compressor Reports

- › Temperature Trendline Report: Reports ambient temperature as well as temperature of every stage in the compressor



### BAUER REMOTE HMI

- › Live connect and remotely control any BAUER compressor(s) in your station
- › Secure log-ins - Only approved team members can access and control your compressor system
- › Saves time and money with instant control no matter your location



### MOBILE DASHBOARDS

- › Quick reference of all of your BAUER compressors at your fingertips
- › Does not require password validation every time app is used
- › Total visual without the Remote HMI control capability (view-only option)
- › Dashboards can be customized to specific customer needs



### NOTIFICATIONS

- › Fault on machine
- › Out of Date or Expired SCBA or SCUBA Cylinders
- › Text, email or push notification alarm(s)
- › Allows for instant, proactive steps to be taken if needed



### BAUER PREDICTIVE ANALYTICS

The BAUER Predictive Analytics capability provides a new proactive dimension to perpetually maintaining customers' compressor systems at peak conditions with minimum downtime. BAUER's Predictive Analytics algorithm uses artificial intelligence to analyze the collected breathing air system information on the BAUER Cloud to predict upcoming maintenance requirements and preventive actions to avoid unplanned shutdowns.



Key Features:



Compressor Features



BAUER Cloud™ RFID Features



# QUICK REFERENCE GUIDE

Model	Block	ACD	Gauges	Purification	Visual CO/ Moisture IND	Fill Assembly	Electrical Start	Hourmeter	Working Pressure
<b>DIVE MATE® BASE</b>									
DMTII 08-E1/E3	IK120II	–	–	P31	S	O	–	S	5000 PSIG
DMTII 08-GK	IK120II	–	–	P31	S	O	–	S	5000 PSIG
DMTII 08-DY	IK120II	–	–	P31	S	O	–	S (vibration type)	5000 PSIG
DMTII 10-E1/E3	IK12.14II	–	–	P41	S	O	–	S	6000 PSIG
DMTII10-GK	IK12.14II	–	–	P41	S	O	–	S	6000 PSIG
DMTII 10-DY	IK12.14II	–	–	P41	S	O	–	S (vibration type)	6000 PSIG
DMTII 13-E1/E3	IK12.14II	–	–	P41	S	O	–	S	6000 PSIG
DMTII 13GK	IK12.14II	–	–	P41	S	O	–	S	6000 PSIG
<b>DIVE MATE ELITE</b>									
DMT08-E1/E3	IK120II	S	S	P31	S	O	–	S	5000 PSIG
DMT08-GK	IK120II	S	S	P31	S	O	S	S	5000 PSIG
DMT08-DY	IK120II	S	S	P31	S	O	–	S (vibration type)	5000 PSIG
DMT10 -E1/E3	IK12.14II	S	S	P41	S	O	–	S	6000 PSIG
DMT10-GK	IK12.14II	S	S	P41	S	O	S	S	6000 PSIG
DMTII 10-DY	IK12.14II	S	S	P41	S	O	–	S (vibration type)	6000 PSIG
DMTII 13-E1/E3	IK12.14II	S	S	P41	S	O	–	S	6000 PSIG
DMTII 13-GK	IK12.14II	S	S	P41	S	O	S	S	6000 PSIG

Model	Block	ACD	Gauges	Purification	Securus	CO Mon	H <sub>2</sub> S Mon	Fill Assembly	Electric Start	Working Pressure
<b>OPEN DESIGNS</b>										
K42-E3/42V-E3	IK22.0	S	S	P10	O	O	O	–	–	5000 PSIG
K60-E3	IK23.0	S	S	P12S	S	O	O	–	–	5000 PSIG
K80-E3	IK25.0	S	S	P14S	S	O	O	–	–	5000 PSIG
K145-E3	IK28.0	S	S	P14S	S	O	O	–	–	5000 PSIG
H35-E3/35V-E3	IK22.42	S	S	P10S	S	O	O	–	–	6000 PSIG
H80-E3	IK25.9	S	S	2x P10S	S	O	O	–	–	6000 PSIG
H96-E3	IK25.18	S	S	2x P10S	S	O	O	–	–	6000 PSIG
<b>ENGINE DRIVEN</b>										
H13-D	IK12.14II	S	S	P2S	S	O	O	–	S	6000 PSIG
H18-D	IK15.11II	S	S	P5S	S	O	O	–	S	6000 PSIG
K20-D	IK150II	S	S	P5S	S	O	O	–	S	5000 PSIG
H25-D	IK18.1II	S	S	P5S	S	O	O	–	S	6000 PSIG
K26-D	IK180II	S	S	P5S	S	O	O	–	S	5000 PSIG
H35-D	IK22.42	S	S	P10S	S	O	O	–	S	6000 PSIG
K42-D	IK22.0	S	S	P10S	S	O	O	–	S	5000 PSIG
K60-D	IK23.0	S	S	P12S	S	O	O	–	S	5000 PSIG

Model	Block	ACD	Gauges	Purification	Securus	CO Mon	H <sub>2</sub> S Mon	Fill Assembly	Electric Start	Working Pressure
<b>VERTECON®</b>										
VEC05-E1/E3	IK100-420	S	S	P2	O	O	O	O	–	6000 PSIG
VEC08-E1/E3	IK120II	S	S	P31	w/P2	O	O	O	–	5000 PSIG
VEC10-E1/E3	IK12.14II	S	S	P2	O	O	O	O	–	6000 PSIG
VEC13-E1/E3	IK12.14II	S	S	P2	O	O	O	O	–	6000 PSIG
VEC18-E1/E3	IK15.11II	S	S	P5	O	O	O	O	–	6000 PSIG
VEC20-E1/E3	IK150II	S	S	P5	O	O	O	O	–	5000 PSIG
VEC25-E1/E3	IK18.1II	S	S	P5	O	O	O	O	–	6000 PSIG
VEC26-E1/E3	IK180II	S	S	P5	O	O	O	O	–	5000 PSIG
<b>VERTICUS®</b>										
VAC5-E1/E3	IK100-420	S	S	P2S	S	O	O	–	–	6000 PSIG
VAC8-E1/E3	IK120II-420	S	S	P2S	S	O	O	–	–	6000 PSIG
VAC10-E1/E3	IK12.14	S	S	P2S	S	O	O	–	–	6000 PSIG
VAC13-E1/E3	IK12.14	S	S	P2S	S	O	O	–	–	6000 PSIG
VAC18-E3	IK15.11II	S	S	P5S	S	O	O	–	–	6000 PSIG
VAC20-E3	IK180II	S	S	P5S	S	O	O	–	–	5000 PSIG
VAC25-E3	IK18.1II	S	S	P5S	S	O	O	–	–	6000 PSIG
VAC26-E3	IK12.180	S	S	P5S	S	O	O	–	–	5000 PSIG

Model	Block	Gauges	Purification	Storage Type	Storage Quantity	Add'l Storage	CO Mon	H <sub>2</sub> S Mon	Remote Fill	Hose Reel	Working Pressure
<b>VERTICUS® PLUS AND UNICUS® 4S</b>											
VT-P 05-E1/E3	IK100-420	S	P2S	UN	2	–	O	O	O	O	6000 PSIG
VT-P 08-E1/E3	IK120II-420	S	P2S	UN	2	–	O	O	O	O	6000 PSIG
VT-P 10-E1/E3	IK12.14II	S	P2S	UN	2	–	O	O	O	O	6000 PSIG
VT-P13-E1/E3	IK12.14II	S	P2S	UN	2	–	O	O	O	O	6000 PSIG
UN 4/10-E1/E3	IK12.14II	S	P2S	ASME	2	O	O	O	O	O	6000 PSIG
UN 4/13-E1/E3	IK12.14II	S	P2S	ASME	2	O	O	O	O	O	6000 PSIG
UN 4/18-E1/E3	IK15.11II	S	P5S	ASME	2	O	O	O	O	O	6000 PSIG
UN 4/20-E1/E3	IK180II	S	P5S	ASME	2	O	O	O	O	O	5000 PSIG
UN 4/25-E1/E3	IK18.1II	S	P5S	ASME	2	O	O	O	O	O	6000 PSIG
UN 4/26-E1/E3	IK1180II	S	P5S	ASME	2	O	O	O	O	O	5000 PSIG

S standard O optional – option not available

## PARTS - DIVE

## JR11-E1/ARMY – OPTIONAL ACCESSORIES

Item	Description	National Stock Number	Part Number
0001	P0 Purification cartridge	NSN 4330-01-350-9101	059183A
0002	Certified air test with documentation		JR11-E1/ARMY/AT
0003	Gasket kit		N06406
0004	Valve overhaul kit	NSN 4820-01-448-1600	N05457
0005	Inlet filter element	NSN 4310-01-447-5922	N04823
0006	Fill gauge		GAG-0010W
0007	Fill gauge with calibration	NSN 6685-01-564-1341	GAG-0010W/CAL
0008	Fill hose 5 ft.		HOS-0123

## OCEANUS-E3Y – OPTIONAL ACCESSORIES

Item	Description	National Stock Number	Part Number
0001	P0 Purification cartridge	NSN 4330-01-350-9101	059183A
0002	Certified air test with documentation		OCEANUS-E3/AT
0003	Gasket kit		N06406
0004	Valve overhaul kit	NSN 4820-01-448-1600	N05457
0005	Inlet filter element	NSN 4310-01-447-5922	N04823
0006	Fill gauge		GAG-0010W
0007	Fill gauge with calibration	NSN 6685-01-564-1341	GAG-0010W/CAL
0008	Fill hose 5 ft.		HOS-0123
0009	Gasket, O-ring and seals kit		GKT-OCEANUS

## OCEANUS-E3/NAVY – OPTIONAL ACCESSORIES

Item	Description	National Stock Number	Part Number
0001	P0 Purification cartridge	NSN 4330-01-350-9101	059183A
0002	Certified air test with documentation		OCEANUS-E3/AT
0003	Inlet filter element	NSN 4310-01-447-5922	N04823
0004	Valve overhaul kit	NSN 4820-01-448-1600	N05457
0005	Gasket kit		N06406
0006	Fill hose 5 ft.		HOS-0123
0007	Fill gauge		GAG-0010W
0008	Fill gauge with calibration	NSN 6685-01-564-1341	GAG-0010W/CAL
0009	Gasket, O-ring and seals kit		GKT-OCEANUS
0010	Plug for 440 VAC		PLU-0164

## OCEANUS-E3Y/NOAA – OPTIONAL ACCESSORIES

Item	Description	National Stock Number	Part Number
0001	P0 Purification cartridge	NSN 4330-01-350-9101	059183A
0002	Certified air test with documentation		OCEANUS-E3/AT
0003	Gasket kit		N06406
0004	Valve overhaul kit	NSN 4820-01-448-1600	N05457
0005	Inlet filter element	NSN 4310-01-447-5922	N04823
0006	Fill gauge		GAG-0010W
0007	Fill gauge with calibration	NSN 6685-01-564-1341	GAG-0010W/CAL
0008	Fill hose 5 ft.		HOS-0123
0009	Gasket, O-ring and seals kit		GKT-OCEANUS

## C-D/DV/NAVY – OPTIONAL ACCESSORIES

Item	Description	National Stock Number	Part Number
0001	P1 Purification cartridge	NSN 4310-01-460-7980	058821A
0002	Certified air test with documentation		C-D/DV/NAVY/AT
0003	Intake filter	NSN 4310-01-460-3415	N00070
0004	Fill hose assembly	NSN 4720-01-476-6250	C-D/DV/NAVY/FH
0005	Gasket, fill hose assembly, calibrated	NSN 6685-01-564-1341	GAG-0010W/CAL
0006	Fill adapter		C-D/DV/NAVY/DFA
0007	Engine fuel filter	NSN 2910-01-310-6566	114250-55121
0008	Engine air filter	NSN 2940-01-310-4495	114250-12580
0009	Engine oil filter	NSN 2815-01-353-7523	114250-35110
0010	Engine pull rope	NSN 2805-01-465-6864	160810-76630-1
0011	Compressor gasket set	NSN 5330-01-460-2664	N06193
0012	V-Belt	NSN 3030-01-497-9924	BET-0013
0013	Moisture element kit	NSN 4310-01-460-4598	ELM-0056
0014	O-Ring kit for purifier		KIT-0068
0015	Fill adapter	NSN 4310-01-460-7069	ADP-0113
0016	Hose assembly	NSN 4720-01-466-9488	HOS-0080
0017	Caster, swivel	NSN 5340-01-461-4356	WHE-0015
0018	Handle	NSN 4310-01-460-6476	HAN-0048/NAVY
0019	O-Ring	NSN 5331-01-233-3247	N04451
0020	Safety valve	NSN 4820-01-460-8443	011656
0021	Safety valve	NSN 4820-01-460-8446	010670
0022	Copper gasket	NSN 5330-01-461-4821	008264
0023	Copper gasket		004479
0024	O-Ring	NSN 5331-01-233-3248	013757



## PARTS - DIVE

### C-D/DV/NAVY (CONTINUED)

Item	Description	National Stock Number	Part Number
0025	Oil pump gasket	NSN 5330-01-460-5428	002010
0026	Piston cylinder gasket	NSN 5330-01-460-2652	003110
0027	Manual condensate drain valve	NSN 4820-01-460-8473	011430
0028	Flange gasket	NSN 5330-01-460-2649	012560
0029	Vortex plate 1	NSN 4310-01-460-6548	012784
0030	Baffle cone	NSN 4310-01-460-6473	012785
0031	Intake filter assembly	NSN 4310-01-460-3404	013758
0032	Prefilter assembly	NSN 4310-01-460-3401	014539
0033	Crankcase vent filter	NSN 4310-01-460-3408	014892
0034	Prefilter with clamp	NSN 4310-01-460-3407	057691
0035	Coalescing element	NSN 4310-01-460-4592	061860
0036	Inter filter assembly	NSN 4310-01-460-3402	067612
0037	Shaft seal	NSN 5330-01-460-2645	N00220
0038	O-Ring	NSN 5331-01-352-1982	N01539
0039	O-Ring	NSN 5331-01-460-5429	N02169
0040	O-Ring	NSN 5331-01-352-1981	N02789
0041	Crankcase vent filter	NSN 4310-01-460-3409	N03207
0042	Copper gasket	NSN 5330-01-461-4898	N04051
0043	Fitting gasket	NSN 5330-01-460-5434	N04499
0044	Copper gasket	NSN 5330-01-461-4899	N01316
0045	O-Ring	NSN 5331-01-084-5330	N02320
0046	Coalescing element	NSN 4310-01-460-4603	N02726
0047	O-Ring	NSN 5331-01-460-2647	N03521
0048	O-Ring	NSN 5331-01-460-5432	N03556
0049	O-Ring	NSN 5331-01-460-5433	N04178
0050	O-Ring	NSN 5331-00-338-1441	N04586
0051	O-Ring	NSN 5331-01-460-5435	N04735
0052	O-Ring	NSN 5331-01-460-5431	N07091
0053	Back-Up O-Ring	NSN 5331-01-461-1631	N04736
0054	Prefilter assembly		HOS-0163
0055	Moisture indicator, visual	NSN 6680-01-461-5793	IND-0015

### C-D/DV/NAVY/SS – OPTIONAL ACCESSORIES

Item	Description	National Stock Number	Part Number
0001	P1 Purification cartridge	NSN 4310-01-460-7980	058821A
0002	Cover		C-D/DV/NAVY/SS/C
0003	Certified air test with documentation		C-D/DV/NAVY/AT
0004	Intake filter	NSN 4310-01-460-3415	N00070
0005	Fill hose assembly	NSN 4720-01-476-6250	C-D/DV/NAVY/FH
0006	Gasket, fill hose assembly, calibrated	NSN 6685-01-564-1341	GAG-0010W/CAL
0007	Fill adapter		C-D/DV/NAVY/DFA
0008	Engine fuel filter	NSN 2910-01-310-6566	114250-55121
0009	Engine air filter	NSN 2940-01-310-4495	114250-12580
0010	Engine oil filter	NSN 2815-01-353-7523	114250-35110
0011	Engine pull rope	NSN 2805-01-465-6864	160810-76630-1
0012	Compressor gasket set	NSN 5330-01-460-2664	N06193
0013	V-Belt	NSN 3030-01-497-9924	BET-0013
0014	Moisture element kit	NSN 4310-01-460-4598	ELM-0056
0015	O-Ring kit for purifier		KIT-0068
0016	Fill adapter	NSN 4310-01-460-7069	ADP-0113
0017	Hose assembly	NSN 4720-01-466-9488	HOS-0080
0018	Caster, swivel		WHE-0031
0019	Handle	NSN 4310-01-460-6476	HAN-0048/NAVY
0020	O-Ring	NSN 5331-01-233-3247	N04451
0021	Safety valve	NSN 4820-01-460-8443	011656
0022	Safety valve	NSN 4820-01-460-8446	010670
0023	Copper gasket	NSN 5330-01-461-4821	008264
0024	Copper gasket		004479
0025	O-Ring	NSN 5331-01-233-3248	013757
0026	Oil pump gasket	NSN 5330-01-460-5428	002010
0027	Piston cylinder gasket	NSN 5330-01-460-2652	003110
0028	Manual condensate drain valve	NSN 4820-01-460-8473	011430
0029	Flange gasket	NSN 5330-01-460-2649	012560
0030	Vortex plate 1	NSN 4310-01-460-6548	012784
0031	Baffle cone	NSN 4310-01-460-6473	012785
0032	Intake filter assembly	NSN 4310-01-460-3404	013758
0033	Prefilter assembly	NSN 4310-01-460-3401	014539
0034	Crankcase vent filter	NSN 4310-01-460-3408	014892
0035	Prefilter with clamp	NSN 4310-01-460-3407	057691
0036	Coalescing element	NSN 4310-01-460-4592	061860
0037	Inter filter assembly	NSN 4310-01-460-3402	067612
0038	Shaft seal	NSN 5330-01-460-2645	N00220
0039	O-Ring	NSN 5331-01-352-1982	N01539
0040	O-Ring	NSN 5331-01-460-5429	N02169

## PARTS - DIVE

### C-D/DV/NAVY/SS (CONTINUED)

Item	Description	National Stock Number	Part Number
0041	O-Ring	NSN 5331-01-352-1981	N02789
0042	Crankcase vent filter	NSN 4310-01-460-3409	N03207
0043	Copper gasket	NSN 5330-01-461-4898	N04051
0044	Fitting gasket	NSN 5330-01-460-5434	N04499
0045	Copper gasket	NSN 5330-01-461-4899	N01316
0046	O-Ring	NSN 5331-01-084-5330	N02320
0047	Coalescing element	NSN 4310-01-460-4603	N02726
0048	O-Ring	NSN 5331-01-460-2647	N03521
0049	O-Ring	NSN 5331-01-460-5432	N03556
0050	O-Ring	NSN 5331-01-460-5433	N04178
0051	O-Ring	NSN 5331-00-338-1441	N04586
0052	O-Ring	NSN 5331-01-460-5435	N04735
0053	O-Ring	NSN 5331-01-460-5431	N07091
0054	Back-Up O-Ring	NSN 5331-01-461-1631	N04736
0055	Latch (Cover)	NSN 5340-01-564-2872	LCH-0063
0056	Prefilter assembly		HOS-0163
0057	Moisture indicator, visual	NSN 6680-01-461-5793	IND-0015

### C-D/DV/MU (CONTINUED)

Item	Description	National Stock Number	Part Number
0013	Caster, swivel	NSN 5340-01-461-4356	WHE-0015
0014	Handle	NSN 4310-01-460-6476	HAN-0048/NAVY
0015	O-Ring	NSN 5331-01-233-3247	N04451
0016	Safety valve	NSN 4820-01-460-8443	011656
0017	Safety valve	NSN 4820-01-460-8446	010670
0018	Copper gasket	NSN 5330-01-461-4821	008264
0019	Copper gasket		004479
0020	O-Ring	NSN 5331-01-233-3248	013757
0021	Oil pump gasket	NSN 5330-01-460-5428	002010
0022	Piston cylinder gasket	NSN 5330-01-460-2652	003110
0023	Manual condensate drain valve	NSN 4820-01-460-8473	011430
0024	Flange gasket	NSN 5330-01-460-2649	012560
0025	Vortex plate 1	NSN 4310-01-460-6548	012784
0026	Baffle cone	NSN 4310-01-460-6473	012785
0027	Intake filter assembly	NSN 4310-01-460-3404	013758
0028	Prefilter assembly	NSN 4310-01-460-3401	014539
0029	Crankcase vent filter	NSN 4310-01-460-3408	014892
0030	Prefilter with clamp	NSN 4310-01-460-3407	057691
0031	Coalescing element	NSN 4310-01-460-4592	061860
0032	Inter filter assembly	NSN 4310-01-460-3402	067612
0033	Shaft seal	NSN 5330-01-460-2645	N00220
0034	O-Ring	NSN 5331-01-352-1982	N01539
0035	O-Ring	NSN 5331-01-460-5429	N02169
0036	O-Ring	NSN 5331-01-352-1981	N02789
0037	Crankcase vent filter	NSN 4310-01-460-3409	N03207
0038	Copper gasket	NSN 5330-01-461-4898	N04051
0039	Fitting gasket	NSN 5330-01-460-5434	N04499
0040	Copper gasket	NSN 5330-01-461-4899	N01316
0041	O-Ring	NSN 5331-01-084-5330	N02320
0042	Coalescing element	NSN 4310-01-460-4603	N02726
0043	O-Ring	NSN 5331-01-460-2647	N03521
0044	O-Ring	NSN 5331-01-460-5432	N03556
0045	O-Ring	NSN 5331-01-460-5433	N04178
0046	O-Ring	NSN 5331-00-338-1441	N04586
0047	O-Ring	NSN 5331-01-460-5435	N04735
0048	O-Ring	NSN 5331-01-460-5431	N07091
0049	Back-Up O-Ring	NSN 5331-01-461-1631	N04736
0050	Prefilter assembly		HOS-0163
0051	Moisture indicator, visual	NSN 6680-01-461-5793	IND-0015

### C-D/DV/MU – OPTIONAL ACCESSORIES

Item	Description	National Stock Number	Part Number
0001	P1 Purification cartridge	NSN 4310-01-460-7980	058821A
0002	Certified air test with documentation		C-D/DV/AT
0003	Intake filter	NSN 4310-01-460-3415	N00070
0004	Fill hose assembly	NSN 4720-01-476-6250	C-D/DV/FH
0005	Gasket, fill hose assembly, calibrated	NSN 6685-01-564-1341	GAG-0010W/CAL
0006	Fill adapter		C-D/DV/DFA
0007	Compressor gasket set	NSN 5330-01-460-2664	N06193
0008	V-Belt	NSN 3030-01-497-9924	BET-0013
0009	Moisture element kit	NSN 4310-01-460-4598	ELM-0056
0010	O-Ring kit for purifier		KIT-0068
0011	Fill adapter	NSN 4310-01-460-7069	ADP-0113
0012	Hose assembly	NSN 4720-01-466-9488	HOS-0080



## PARTS - DIVE

## C-D/DV/MU/SS – OPTIONAL ACCESSORIES

Item	Description	National Stock Number	Part Number
0001	P1 Purification cartridge	NSN 4310-01-460-7980	058821A
0002	Cover		C-D/DV/SS/C
0003	Certified air test with documentation		C-D/DV/AT
0004	Intake filter	NSN 4310-01-460-3415	N00070
0005	Fill hose assembly	NSN 4720-01-476-6250	C-D/DV/FH
0006	Gasket, fill hose assembly, calibrated	NSN 6685-01-564-1341	GAG-0010W/CAL
0007	Fill adapter		C-D/DV/DFA
0008	Compressor gasket set	NSN 5330-01-460-2664	N06193
0009	V-Belt	NSN 3030-01-497-9924	BET-0013
0010	Moisture element kit	NSN 4310-01-460-4598	ELM-0056
0011	O-Ring kit for purifier		KIT-0068
0012	Fill adapter	NSN 4310-01-460-7069	ADP-0113
0013	Hose assembly	NSN 4720-01-466-9488	HOS-0080
0014	Caster, swivel		WHE-0031
0015	Handle	NSN 4310-01-460-6476	HAN-0048/NAVY
0016	O-Ring	NSN 5331-01-233-3247	N04451
0017	Safety valve	NSN 4820-01-460-8443	011656
0018	Safety valve	NSN 4820-01-460-8446	010670
0019	Copper gasket	NSN 5330-01-461-4821	008264
0020	Copper gasket		004479
0021	O-Ring	NSN 5331-01-233-3248	013757
0022	Oil pump gasket	NSN 5330-01-460-5428	002010
0023	Piston cylinder gasket	NSN 5330-01-460-2652	003110
0024	Manual condensate drain valve	NSN 4820-01-460-8473	011430
0025	Flange gasket	NSN 5330-01-460-2649	012560
0026	Vortex plate 1	NSN 4310-01-460-6548	012784
0027	Baffle cone	NSN 4310-01-460-6473	012785
0028	Intake filter assembly	NSN 4310-01-460-3404	013758
0029	Prefilter assembly	NSN 4310-01-460-3401	014539
0030	Crankcase vent filter	NSN 4310-01-460-3408	014892
0031	Prefilter with clamp	NSN 4310-01-460-3407	057691
0032	Coalescing element	NSN 4310-01-460-4592	061860
0033	Inter filter assembly	NSN 4310-01-460-3402	067612
0034	Shaft seal	NSN 5330-01-460-2645	N00220
0035	O-Ring	NSN 5331-01-352-1982	N01539
0036	O-Ring	NSN 5331-01-460-5429	N02169
0037	O-Ring	NSN 5331-01-352-1981	N02789

## C-D/DV/MU/SS (CONTINUED)

Item	Description	National Stock Number	Part Number
0038	Crankcase vent filter	NSN 4310-01-460-3409	N03207
0039	Copper gasket	NSN 5330-01-461-4898	N04051
0040	Fitting gasket	NSN 5330-01-460-5434	N04499
0041	Copper gasket	NSN 5330-01-461-4899	N01316
0042	O-Ring	NSN 5331-01-084-5330	N02320
0043	Coalescing element	NSN 4310-01-460-4603	N02726
0044	O-Ring	NSN 5331-01-460-2647	N03521
0045	O-Ring	NSN 5331-01-460-5432	N03556
0046	O-Ring	NSN 5331-01-460-5433	N04178
0047	O-Ring	NSN 5331-00-338-1441	N04586
0048	O-Ring	NSN 5331-01-460-5435	N04735
0049	O-Ring	NSN 5331-01-460-5431	N07091
0050	Back-Up O-Ring	NSN 5331-01-461-1631	N04736
0051	Latch (Cover)	NSN 5340-01-564-2872	LCH-0063
0052	Prefilter assembly		HOS-0163
0053	Moisture indicator, visual	NSN 6680-01-461-5793	IND-0015

## MII-D/DV – OPTIONAL ACCESSORIES

Item	Description	National Stock Number	Part Number
0001	P1 Purification cartridge	NSN 4310-01-460-7980	058821A
0002	Certified air test with documentation		MII-D/DV/AT
0003	Intake filter	NSN 4310-01-556-0748	N25950
0004	Fill hose assembly	NSN 4720-01-476-6250	C-D/DV/NAVY/FH
0005	Gasket, fill hose assembly, calibrated	NSN 6685-01-564-1341	GAG-0010W/CAL
0006	Fill adapter		C-D/DV/NAVY/DFA
0007	Compressor block heater		HTR-0112
0008	Diesel engine block heater		HTR-0118
0009	Package Hypalon® type cover		COVER

## PARTS - DIVE & FIRE

### VERTECON® – OPTIONAL ACCESSORIES

Item	Description	Part Number
0001	Automatic condensate drain system (VEC08)	ACD/3 STG
0002	Automatic condensate drain system (VEC13)	ACD/4 STG
0003	Electronic carbon monoxide monitor with calibration kit	MNR-29/CAL**
0004	Electronic purification monitoring system	SECURUS
0005	Interstage pressure gauges	GAUGES/3 STG
0006	Interstage pressure gauges	GAUGES/4 STG
0007	Dual pressure switch	DPS-2
0008	VEC08 Standard purification cartridge	080114
0009	VEC20 Standard dryer cartridge	058825
	VEC20 Standard purification cartridge	058827
0010	VEC26 Standard dryer cartridge	058825
	VEC26 Standard purification cartridge	058827
0011	VEC05 SECURUS purification cartridge	060037
0012	VEC13 Standard purification cartridge	058827
0013	VEC25 Standard dryer cartridge	058825
	VEC25 Standard purification cartridge	058827
0014	VEC20 Standard dryer cartridge	058825
	VEC20 SECURUS purification cartridge	060037
0015	VEC26 Standard dryer cartridge	058825
	VEC26 SECURUS purification cartridge	060037
0016	VEC13 SECURUS purification cartridge	060037
0017	VEC18 Standard dryer cartridge	058825
	VEC18 SECURUS purification cartridge	060037
0018	VEC25 Standard dryer cartridge	058825
	VEC25 SECURUS purification cartridge	060037
0019	VEC08 Maintenance kit, Block	500 hrs: A-120II-F7-A1   1000 hrs: A-120II-F7-AB1   2000 hrs: A-120II-F7-ABC1
0020	VEC20 Maintenance kit, Block	500 hrs: A-150II-F11-A1   1000 hrs: A-150II-F11-AB1   2000 hrs: A-150II-F11-ABC1
0021	VEC26 Maintenance kit, Block	500 hrs: A-180II-F5/6-A1   1000 hrs: A-180II-F5/6-AB1   2000 hrs: A-180II-F5/6-ABC1
0022	VEC05 Maintenance kit, Block	500 hrs: A-100II-400-A1   1000 hrs: A-100II-400-AB1   2000 hrs: A-100II-400-ABC1
0023	VEC13 Maintenance kit, Block	500 hrs: A-12.14II-F4/6-A1   1000 hrs: A-12.14II-F4/6-AB1   2000 hrs: A-12.14II-F4/6-ABC1
0024	VEC18 Maintenance kit, Block	500 hrs: A-15.11II-F1-A1   1000 hrs: A-15.11II-F1-AB1   2000 hrs: A-15.11II-F1-ABC1
0025	VEC25 Maintenance kit, Block	500 hrs: A-18.11II-F8-A1   1000 hrs: A-18.11II-F8-AB1   2000 hrs: A-18.11II-F8-ABC1

### BASIC PACKAGE II – OPTIONAL ACCESSORIES

Item	Description	Part Number
0004	Electronic carbon monoxide monitor with calibration kit	MNR-29/CAL**
0005	Electronic purification monitoring system	SECURUS
0006	Dual pressure switch	DPS-2

### VERTICUS™ – OPTIONAL ACCESSORIES

Item	Description	Part Number
0001	Electronic carbon monoxide with calibration kit	MNR-29/CAL**
0002	Dual pressure switch	DPS-2
0003	VAC8 SECURUS purification cartridge	060037
0004	VAC13 SECURUS purification cartridge	060037
0005	VAC18 Standard dryer cartridge	058825
	VAC18 SECURUS purification cartridge	060037
0006	VAC25 Standard dryer cartridge	058825
	VAC25 SECURUS purification cartridge	060037
0009	VAC8 Maintenance kit, Block	500 hrs: A-120II-F7-A1   1000 hrs: A-120II-F7-AB1   2000 hrs: A-120II-F7-ABC1
0010	VAC13 Maintenance kit, Block	500 hrs: A-12.14II-F4/6-A1   1000 hrs: A-12.14II-F4/6-AB1   2000 hrs: A-12.14II-F4/6-ABC1
0011	VAC18 Maintenance kit, Block	500 hrs: A-15.11II-F1-A1   1000 hrs: A-15.11II-F1-AB1   2000 hrs: A-15.11II-F1-ABC1
0012	VAC25 Maintenance kit, Block	500 hrs: A-18.11II-F8-A1   1000 hrs: A-18.11II-F8-AB1   2000 hrs: A-18.11II-F8-ABC1

\*\*The GSA version is strictly for factory installed applications sold as an optional feature with a new compressor purchase.

### VERTICUS™ PLUS – OPTIONAL ACCESSORIES

Item	Description	Part Number
0001	Electronic carbon monoxide monitor	MNR-29/CAL**
0002	ASME storage in lieu of DOT	ASME/STORAGE
0003	Remote fill hose connection	/RF/REG
0004	Remote fill hose connection with regulator	MU/RF/REL-9
0005	Interstage pressure gauges 3-stage compressor	GAUGES/3 STG
0006	Interstage pressure gauges 4-stage compressor	GAUGES/4 STG
0007	Dual-fill, HIGH/LOW quick connect fill system	DUAL-FILL/1 POSITION
0008	Dual-fill, HIGH/LOW quick connect fill system	DUAL-FILL/2 POSITION
0009	Tri-fill, HIGH/LOW/SCUBA quick connection fill system	TRI-FILL/1 POSITION
0010	Tri-fill, HIGH/LOW/SCUBA quick connection fill system	TRI-FILL/2 POSITION
0011	VT-P/8 SECURUS purification cartridge	060037
0012	VT-P/10 SECURUS purification cartridge	060037
0013	VT-P/8 Maintenance kit, Block	500 hrs: A-120II-F7-A1   1000 hrs: A-120II-F7-AB1   2000 hrs: A-120II-F7-ABC1
0014	VT-P/10 Maintenance kit, Block	500 hrs: A-12.14II-F4/6-A1   1000 hrs: A-12.14II-F4/6-AB1   2000 hrs: A-12.14II-F4/6-ABC1
0015	Maintenance kit, Regulator	GOP-0046
0016	Maintenance kit, Isolation valve	KIT-0477



# PARTS - FIRE

## UNICUS® 4 – OPTIONAL ACCESSORIES

Item	Description	Part Number
0001	Electronic carbon monoxide monitor	MNR-29/CAL**
0002	6000 PSIG cylinder (each additional)	CYL-9/6K
0003	Remote fill hose connection	/RF/REG
0004	UN4 Remote fill hose connection with regulator	UNIII/RF/REL-9
0005	Dual-fill, HIGH/LOW quick connect fill system	DUAL-FILL/1 POSITION
0006	Dual-fill, HIGH/LOW quick connect fill system	DUAL-FILL/2 POSITION
0007	Dual-fill, HIGH/LOW quick connect fill system	DUAL-FILL/3 POSITION
0008	Tri-fill, HIGH/LOW/SCUBA quick connection fill system	TRI-FILL/1 POSITION
0009	Tri-fill, HIGH/LOW/SCUBA quick connection fill system	TRI-FILL/2 POSITION
0010	Tri-fill, HIGH/LOW/SCUBA quick connection fill system	TRI-FILL/3 POSITION
0011	UN 4/13 SECURUS Purification cartridge	060037
0012	UN 4/18 Standard dryer cartridge	058825
	UN 4/18 SECURUS Purification cartridge	060037
0013	UN 4/25 Standard dryer cartridge	058825
	UN 4/25 SECURUS Purification cartridge	060037

## UNICUS® 4 PARTS (CONTINUED)

Item	Description	Part Number
0017	UN 4/13 Maintenance kit, Block	500 hrs: A-12.14II-F4/6-A1   1000 hrs: A-12.14II-F4/6-AB1   2000 hrs: A-12.14II-F4/6-ABC1
0018	UN 4/18 Maintenance kit, Block	500 hrs: A-15.11II-F1-A1   1000 hrs: A-15.11II-F1-AB1   2000 hrs: A-15.11II-F1-ABC1
0019	UN 4/25 Maintenance kit, Block	500 hrs: A-18.11I-F8-A1   1000 hrs: A-18.11I-F8-AB1   2000 hrs: A-18.11I-F8-ABC1
0020	Maintenance kit, Regulator	GOP-0046
0021	Maintenance kit, Isolation valve	KIT-0477

\*\*The GSA version is strictly for factory installed applications sold as an optional feature with a new compressor purchase.

## DDTR26-WRAF/GSA – OPTIONAL ACCESSORIES

Item	Description	Part Number
0001	Spare tire and wheel chocks with fender well storage	OPTION PACKAGE A
0002	75 ft. hose reel and interior lights	OPTION PACKAGE B
0003	2 5/16" ball hitch	OPTION PACKAGE C
0004	SECURUS Purification cartridge	060037
0005	Compressor block maintenance kit	500 hrs: A-180II-F5/6-A1   1000 hrs: A-180II-F5/6-AB1   2000 hrs: A-180II-F5/6-ABC1
0006	Regulator, HP panel	REG-0039
0007	Maintenance kit, Regulator	GOP-0046
0008	Maintenance kit, Panel valve	KIT-0477
0009	Light mast, Retractable	LIT-0132
0010	Light cluster	LIT-0133
0011	Light bulb	LIT-0137

## TCOM® TRAILER – OPTIONAL ACCESSORIES

Item	Description	Part Number
0001	Telescoping light mast with snorkel tube for compressor inlet	OPTION PACKAGE A
0002	Spare tire and wheel chocks with fender well storage	OPTION PACKAGE B
0003	75ft. hose reel and interior lights	OPTION PACKAGE C
0004	2 5/16" ball hitch	OPTION PACKAGE D
0005	TCOM - 13 Standard dryer cartridge	058825
	TCOM - 13 SECURUS purification cartridge	060037
0006	TCOM - 25 Standard dryer cartridge	058825
	TCOM - 25 SECURUS purification cartridge	060037
0007	TCOM - 13 Maintenance kit, Block	500 hrs: A-12.14II-F4/6-A1   1000 hrs: A-12.14II-F4/6-AB1   2000 hrs: A-12.14II-F4/6-ABC1
0008	TCOM - 25 Maintenance kit, Block	500 hrs: A-18.11I-F8-A1   1000 hrs: A-18.11I-F8-AB1   2000 hrs: A-18.11I-F8-ABC1
0009	Regulator, HP panel	REG-0039
0010	Maintenance kit, Regulator	GOP-0046
0011	Maintenance kit, Panel valve	KIT-0477
0012	Light Mast, Retractable	LIT-0132
0013	Light cluster	LIT-0133
0014	Light bulb	LIT-0137

## TCOM LITE® – OPTIONAL ACCESSORIES

Item	Description	Part Number
0001	TCL - 13 Standard dryer cartridge	058825
	TCOM - 13 SECURUS purification cartridge	060037
0002	TCL - 25 Standard dryer cartridge	058825
	TCL - 25 SECURUS purification cartridge	060037
0003	TCL - 13 Maintenance kit, Block	500 hrs: A-12.14II-F4/6-A1   1000 hrs: A-12.14II-F4/6-AB1   2000 hrs: A-12.14II-F4/6-ABC1
0004	TCL - 25 Maintenance kit, Block	500 hrs: A-18.11I-F8-A1   1000 hrs: A-18.11I-F8-AB1   2000 hrs: A-18.11I-F8-ABC1
0005	Regulator, HP panel	REG-0039
0006	Maintenance kit, Regulator	GOP-0046
0007	Maintenance kit, Panel valve	KIT-0477

## CFS5.5® – OPTIONAL ACCESSORIES

Item	Description	Part Number
0001	Single function top mount cascade controls	SF TM/CSCD
0002	Dual function top mount cascade controls	DF TM/CSCD
0003	Remote fill connection with high pressure regulator	/Rf/REG

## PARTS



### QUALITY AND RELIABILITY

Our factory-original replacement parts ensures when maintenance or repair is performed, you are restoring the unit to its original specifications and performance.

- 1. Purification
- 2. Gaskets and Seals
- 3. Lubricants
- 4. Fill Hose and Assemblies
- 5. Valves
- 6. Air Intake Filters
- 7. All 10,000+ Parts



**7 PLUS, OVER 10,000 OEM PARTS**

### COMPATIBILITY

We configure our designs with interchangeability and our end user in mind. You can count on parts being available for all BAUER models.

**PartsSales@BauerComp.com or 1-(844)-500-5822**

## GLOBAL SERVICE



- B** BAUER Germany & BAUER Norfolk
- BAUER Branches
- BAUER Service Centers/Distributors



### SERVICE AND SUPPORT

Our compressors are designed with you in mind. Easy to use manuals guide you through clear, mechanically accessible repairs. Our worldwide distribution network was developed to assist in after-sales support, along with product and maintenance parts assistance.

### FROM THE SOURCE

BAUER COMPRESSORS INC., is certified with **ISO 9001:2015** quality processes providing you with confidence that cannot be duplicated by sub-standard after-market parts and service.



## TRAINING



BAUER COMPRESSORS INC. offers a variety of on site & off site Training Schools. Our on site classes are held at our BAUER Training Facility and are taught by the same people that help manufacture, test and service our products. From electrical systems to hands-on break downs, we cover all areas of compressor operation.

### TRAINING TOPICS

Basic mechanical theory, control system theory (electric and pneumatic) along with troubleshooting for all BAUER systems.

Class schedule and course registration at:

**www.BauerCustomerTraining.com**



## BAUER HELPDESK



### MECHANICAL & ELECTRICAL

Total customer satisfaction is our top priority. BAUER provides 24-7 phone tech and troubleshooting support at our BAUER Helpdesk. Our support continues throughout our warranty period and beyond.

**>>> For BAUER Helpdesk please email: [CustomerService@BauerComp.com](mailto:CustomerService@BauerComp.com) or call at:**

**+1 (844)-500-5822**

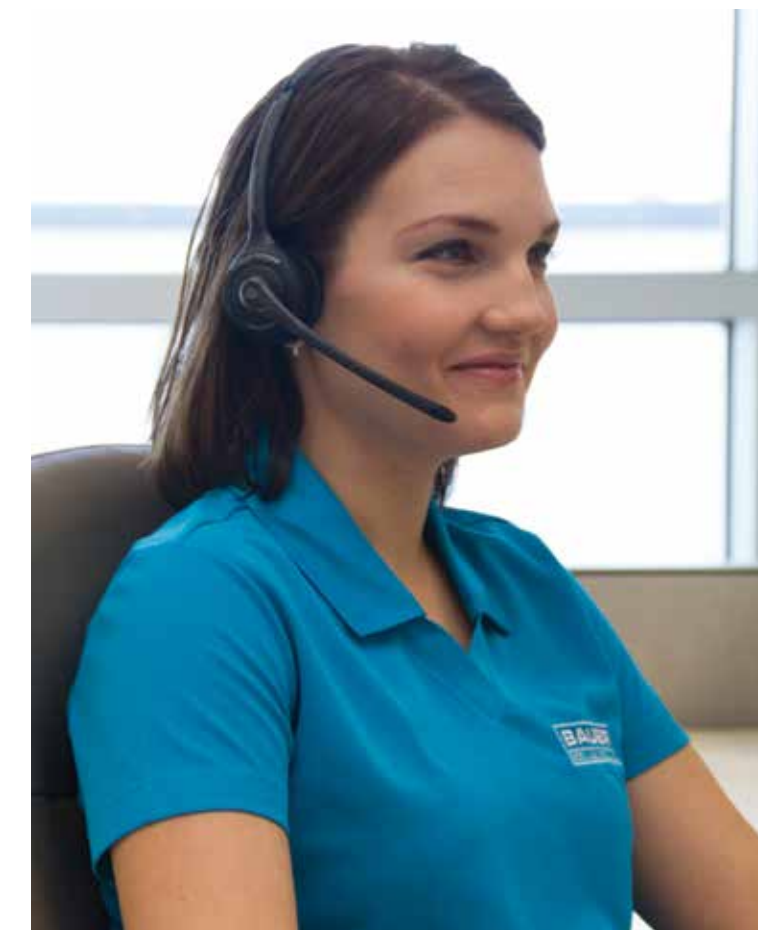

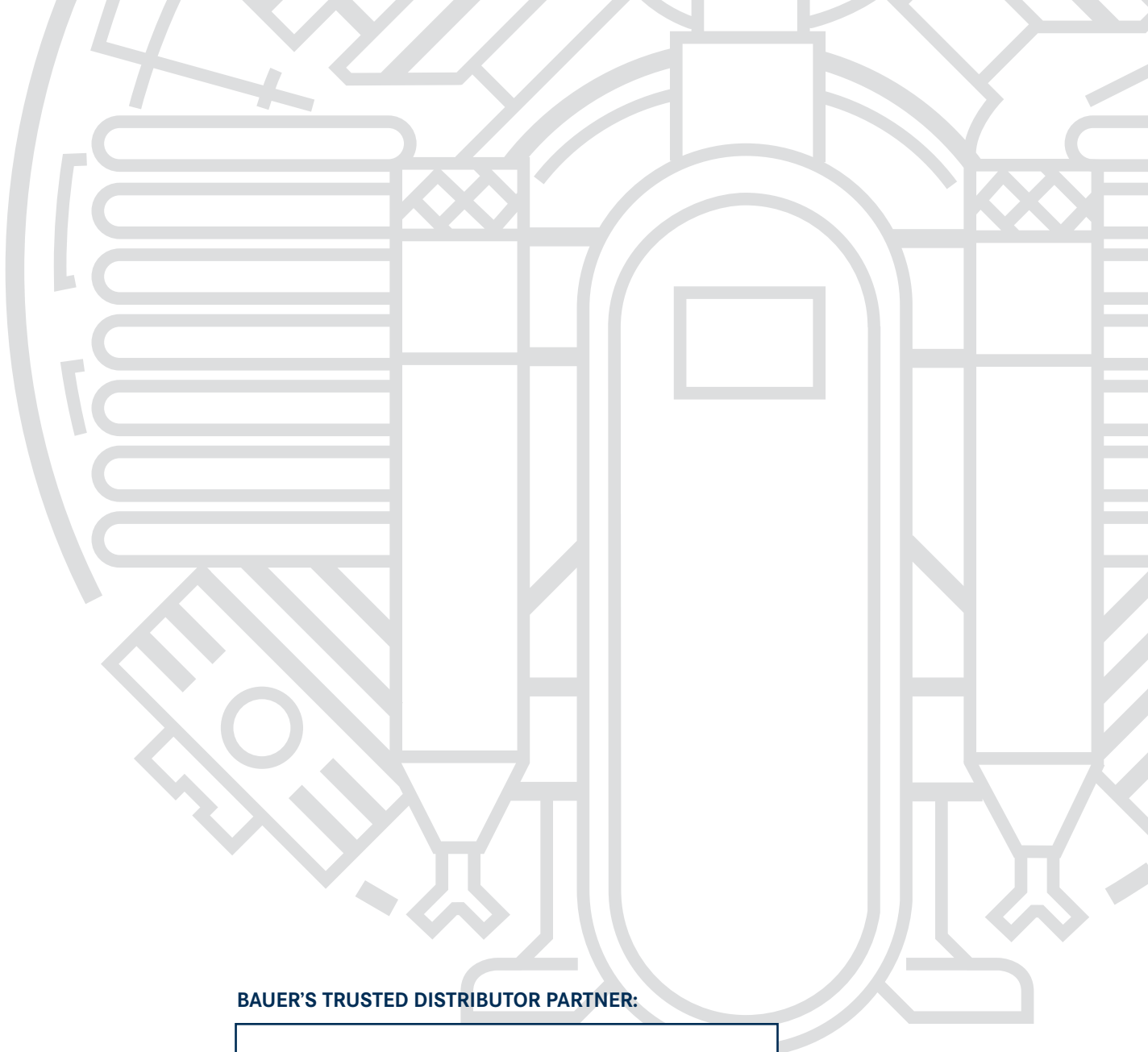

**BAUER'S TRUSTED DISTRIBUTOR PARTNER:**

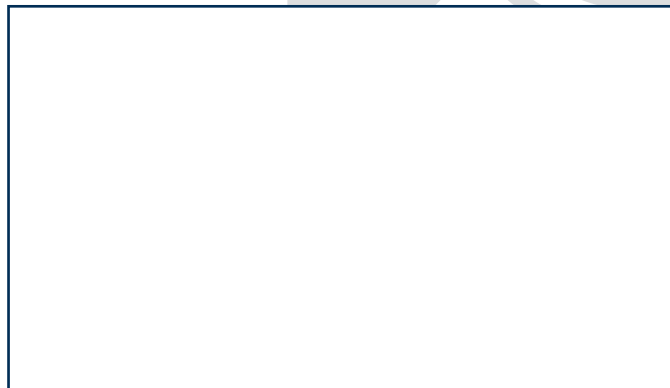

**U.S. HEADQUARTERS:**  
**BAUER COMPRESSORS, INC.**  
1328 Azalea Garden Road  
Norfolk, VA 23502  
Tel. +1 (757) 855-6006  
Fax +1 (757) 857-1041  
**SLS@BauerComp.com**  
**www.BauerComp.com**

**U.S. BRANCHES:**  
**BAUER MIAMI**  
Tel. +1 (954) 746-2504  
Fax +1 (954) 746-2510  
**BFLSales@BauerComp.com**

**BAUER SAN FRANCISCO**  
267 East Airway Boulevard  
Livermore, CA 94551  
Tel. +1 (925) 449-7210  
Fax +1 (925) 449-7201  
**BauerSF@BauerComp.com**

**BAUER NORTHEAST**  
2124 State Route 89  
Seneca Falls, NY 13148  
Tel. +1 (315) 568-5520  
Fax +1 (315) 568-5520  
**Tim.Burgess@BauerComp.com**

**[www.BauerBreathingAir.com](http://www.BauerBreathingAir.com)**

1174.05.23.300 GP  
Subject to technical changes